

# VISION IMPLEMENTATION PLAN APPENDICES

<b>1</b>	<b>Initial Study Corridor.....</b>	<b>1-1</b>
	Service Areas.....	1-1
	San Jose to Oakland Service Area .....	1-1
	Oakland to Sacramento Service Area .....	1-3
	Sacramento to Auburn Service Area.....	1-5
	Evaluation Criteria.....	1-6
	Service Criteria.....	1-6
	Design Criteria.....	1-6
	Recommended Capital Improvements .....	1-6
	San Jose to CP Coast .....	1-7
	CP Coast to Newark.....	1-7
	Newark to Oakland .....	1-7
	Jack London Square (JLS).....	1-8
	Oakland to North Richmond .....	1-8
	North Richmond to Benicia.....	1-9
	Sacramento to Roseville.....	1-9
	Roseville to Auburn .....	1-9
	Systemwide Improvements .....	1-10
<b>2</b>	<b>Freight Mitigation Concepts .....</b>	<b>2-1</b>
	Service Areas.....	2-1
	San Jose to Oakland Service Area .....	2-1
	Oakland to Sacramento Service Area .....	2-1
	Sacramento to Auburn Service Area.....	2-4
	Evaluation Criteria.....	2-4
	Service Criteria.....	2-4
	Design Criteria.....	2-4
	Recommended Capital Improvements .....	2-4
	San Jose to Newark.....	2-5
	Newark to Oakland .....	2-5
	Jack London Square (JLS).....	2-5
	Martinez to Sacramento .....	2-5
<b>3</b>	<b>Jack London Square Alternatives Evaluation.....</b>	<b>3-1</b>
	Background .....	3-1
	Issues Identified .....	3-1
	Alternatives Identified and Eliminated from Further Consideration .....	3-2
	Recommended Feasible Alternatives.....	3-3

<b>4</b>	<b>Operating Plan, Travel Times &amp; Operating Costs</b> .....	<b>4-1</b>
	Operating Plan .....	4-1
	Travel Times .....	4-2
	Travel Times .....	4-9
	Operating Costs.....	4-11
<b>5</b>	<b>Vision Implementation Strategy</b> .....	<b>5-1</b>
	Project Prioritization.....	5-1
	Implementation Phasing Strategy.....	5-6
	Project Costs.....	5-6
<b>6</b>	<b>Funding Options</b> .....	<b>6-1</b>
	Summary of Funding Needs .....	6-1
	Overview of Capital Funding Sources.....	6-2
	Conclusion.....	6-9
<b>7</b>	<b>Potential Impacts of BART Plans</b> .....	<b>7-1</b>

# 1 INITIAL STUDY CORRIDOR

The Capitol Corridor Vision Plan identified three potential corridors through which a dedicated passenger-only rail system is potentially feasible. The VIP selected and analyzed the corridor that appeared to best achieve the goals of the Vision Plan at this point in time. Further alternative analyses and environmental assessment is required before a locally preferred alternative can be selected.

The initial study corridor (ISC) primarily follows the UPRR Coast, Martinez, and Roseville Subdivisions between San Jose and Auburn. The ISC was divided into three distinct service areas: San Jose to Oakland, Oakland to Sacramento, and Sacramento to Auburn. A future service to Monterey County is currently being considered, but was not included in the scope of this study. The service areas were subsequently divided into geographic segments that allow incremental service and speed increases as projects are completed within each geographic area. The service areas and geographic segments are described below.

## SERVICE AREAS

### San Jose to Oakland Service Area

The CCJPA currently operates seven round trips daily between San Jose and Oakland on portions of Caltrain and the UPRR's Coast and Niles Subdivisions (see Figure 1-1). The VIP routes Capitol Corridor trains off of the Niles Subdivision onto the Coast Subdivision between Newark and Oakland. The service area of this portion of Capitol Corridor is approximately 43 miles long and is sub-divided into four distinct geographic segments as follows:

- **San Jose to CP Coast (SJ-CPC):** The San Jose to Control Point (CP) Coast segment begins in the vicinity of the existing Caltrain Tamien layover facility (MP 49.5) on the Coast Subdivision and extends north approximately 4.8 miles to CP Coast (MP 44.7). This segment, owned and operated by Caltrain, includes Caltrain's Tamien, Diridon, College Park, and Santa Clara Stations. Capitol Corridor trains currently stop at Diridon and Santa Clara Stations. If CCJPA constructs a new layover facility south of Tamien, Capitol Corridor trains could potentially stop at Tamien in the future.
- **CP Coast to Newark (CPC-NWK):** The Capitol Corridor line continues northward from CP Coast on UPRR's Coast Subdivision 13.7 miles to Newark Junction (MP 31.0). The primarily single-track line crosses through Alviso Salt Flats. Capitol Corridor's Santa Clara Great American Station (MP 40.8) is located in this segment, and a proposed Fremont/Newark Station near the Dumbarton Bridge allowing for intermodal connections.

Figure 1-1 San Jose to Oakland Service Area



- **Newark to Oakland (NWK-OAK):** At Newark the Capitol Corridor line continues north on the Coast Subdivision to Elmhurst Junction (MP 13.5) where it crosses over the UPRR Niles Subdivision and joins the UPRR Oakland Subdivision. The line parallels the Oakland Subdivision for 3.3 miles and the Niles Subdivision for 3.4 miles to just south of Jack London Square in Oakland. The primarily single-track segment to Elmhurst Junction is approximately 24.2 miles in length. Capitol Corridor's Oakland Coliseum Station (MP 12.0), is relocated from the Niles Subdivision adjacent to the BART station.
- **Jack London Square (JLS):** The Jack London Square segment is located between the UPRR's East (MP 7.7) and West Oakland (MP 6.4) rail yards on the Niles Subdivision and is 1.3 miles in length. The segment also includes approximately 1,600 feet of in-street double main track on Embarcadero Boulevard. Capitol Corridor's Jack London Station (MP 6.8) is located in this segment.

## Oakland to Sacramento Service Area

The CCJPA currently operates fifteen round trips daily between Oakland and Sacramento on the UPRR's Martinez Subdivision. In addition to the Capitol Corridor service, Amtrak operates once daily Coast Starlight and California Zephyr long distance passenger trains between Oakland and Sacramento and the five daily round trips of the San Joaquins service between Oakland and Richmond for a total of 44 passenger trains a day.

With the VIP, Capitol Corridor trains continue on the existing route as shown in Figure 1-2, but includes a Franklyn Canyon bypass alignment to avoid coastal areas between Richmond and Martinez. The service area is approximately 88 miles long and is divided into three distinct geographic segments as follows:



Figure 1-2 Oakland to Sacramento Service Area



- **Oakland to North Richmond (OAK-RCH):** From UPRR’s West Oakland rail yard, the Capitol Corridor line continues north on the UPRR’s Niles and Martinez Subdivisions from Niles MP 6.4 to Martinez MP 15.6 just north of Richmond, approximately 16 miles. Capitol Corridor’s Emeryville (MP 4.4), Berkeley (MP 6.3), and Richmond (MP 12.2) Stations are located in this segment.
- **North Richmond to Benicia (RCH-BEN):** At this point the line diverges from the UPRR right-of-way onto the proposed Franklyn Canyon Bypass. The Capitol Corridor line parallels the BNSF Stockton Subdivision for approximately 5.8 miles to Franklin Canyon where the line enters a new tunnel alignment to Martinez. The bypass is approximately 6.8 miles in length and includes approximately 5.2 miles of twin bore tunnels. The line rejoins the UPRR Martinez Subdivision (MP 30.0) and continues north across the Carquinez Strait to Benicia (MP 35.0). Capitol Corridor’s Martinez Station (MP 31.6) is located in this segment. The segment also includes a potential future station adjacent to Hwy 80/ Hwy 4 in the City of Hercules.
- **Benicia to Sacramento (BEN-SAC):** From Benicia, the Capitol Corridor line continues northeast for 53.8 miles to Sacramento (MP 88.8). Capitol Corridor’s Suisun (MP 48.9), Davis (MP 75.5), and Sacramento (MP 88.8) Stations are located in this segment, and a station at Fairfield-Vacaville (MP 53.9) is planned.

## Sacramento to Auburn Service Area

The CCJPA currently operates one daily round trip between Sacramento and Auburn on UPRR's Martinez and Roseville Subdivisions. In addition to the Capitol Corridor service, Amtrak operates daily Coast Starlight and California Zephyr long distance passenger trains over portions of this line. The VIP continues to route Capitol Corridor trains on the existing rail alignment between Sacramento and Roseville (see Figure 1-3). East of Roseville, the Capitol Corridor trains use the Mainline No.1 (westbound) alignment to Auburn instead of the Mainline No.2 eastbound alignment as it currently does. The service area is approximately 35 miles long and is divided into two distinct geographic segments as follows:

- **Sacramento to Roseville (SAC-ROS):** From the Sacramento Station (MP 88.8) the Capitol Corridor line continues 17.6 miles east on the Martinez Subdivision to Roseville Station (MP 106.4). Capitol Corridor's Roseville Station (MP 106.4) is located in this segment.
- **Roseville to Auburn (ROS-AUB):** From Roseville (MP 106.4) the line continues on the Roseville Subdivision's Mainline No. 1 to Auburn (MP 124.0), approximately 17.6 miles. Capitol Corridor's Rocklin (MP 109.2) and Auburn (MP 124.0) Stations are located in this segment.

Figure 1-3 Sacramento to Auburn Service Area



## EVALUATION CRITERIA

### Service Criteria

The VIP envisions a modern passenger service along the I-80/I-880 freeway corridor designed to provide at a minimum:

- Safe and reliable operations;
- Environmentally sustainable operations (carbon neutral to positive);
- Competitive travel times with automobiles;
- High frequency of service to regions employment and residential centers; and
- Modal connectivity to regions transit systems.

The rail service criteria used in this study was modeled after international passenger systems and includes:

- Dedicated passenger-only tracks on either:
  - Separated rights-of-way wherever practical, or
  - Shared corridors with freight on separate tracks in congested urban areas.
- Use of existing rights-of-way to the extent possible to minimize property acquisitions and environmental impacts.
- Speeds competitive with automobile travel
  - Travel times between stations competitive with automobiles
  - Higher top speeds (90 mph - 125 mph) depending on physical constraints within the line segment.
- Service levels based on:
  - AM/PM peak frequency every 15 minutes
  - Off-peak frequency every 30 minutes
  - Express service between major city centers
  - Limited shuttle service between major employment centers
  - Extended service hours from 5:00 AM to 12:00 PM
- Modal connectivity
  - Timed transfers at major intermodal centers
  - Direct transfers (cross platform where possible) to regional transit systems
- Beneficial uses of proposed improvements, including sea level rise protection and tidelands restoration/preservation

### Design Criteria

Conceptual corridor alignment plans were prepared based on the following design criteria:

- Operations up to 125 mph: AREMA Manual for Railway Engineering dated 2015.

## RECOMMENDED CAPITAL IMPROVEMENTS

In order to achieve the service goals and objectives of the Vision Plan, a long-term program of capital improvements and right-of-way acquisitions was developed for each geographic segment within the three service areas. Corridor alignment drawings were developed (see



<http://www.capitolcorridor.org/vision-plan/> for corridor drawings) to verify the feasibility of the proposed improvements and identify potential right-of-way impacts. The drawings were based on available aerial images and are at an early conceptual design level (5%-10%). Table 1-1 summarizes the proposed improvements needed to achieve the vision of a dedicated passenger system for the region. The following is a brief description of the proposed improvements by geographic segment, starting in San Jose heading northeast to Auburn.

## San Jose to CP Coast

- **San Jose to Santa Clara Phase 3 & 4 Track Improvements:** This Caltrain-led project provides a new 4<sup>th</sup> main track between Diridon Station and CP Coast. The project also modifies the north and south leads into the station to allow for parallel train movements into and out of the station. The addition of high speed rail service to Diridon Station by 2025 may require modifications to the proposed design, additional platforms at Diridon Station, and a fifth main track between San Jose and CP Coast. The California High Speed Rail Authority (CHSRA) is currently analyzing this segment as part of the San Jose to Merced NEPA/CEQA environmental assessment.

## CP Coast to Newark

- **Right-of-Way Acquisition:** Within this segment a 35-foot to 45-foot strip of right-of-way is acquired from the UPRR's Coast Subdivision and adjoining public and private properties between CP Coast (MP 44.6) and Newark Junction (MP 31.0). A wider 60-foot to 80-foot strip of right-of-way is proposed across the Alviso Salt Flats to allow the track to be raised to protect against sea level rise, provide for habitat enhancements, and improve sediment transport through restored tidal and alluvial flow.
- **Double Track CP Coast to Newark:** Between CP Coast and Newark 14.5 miles of new passenger double main track is constructed including a new 6,000 foot bridge across the Alviso Salt Flats to improve sediment transport to the existing tidelands. The Santa Clara Great America Station is expanded to include a center platform and improved connectivity to the planned Santa Clara City Place development. The existing UPRR main track remains in place or is shifted as required to allow construction of the passenger double track within a shared corridor.
- **Grade Separations:** The project provides for the construction of seven new grade separations, closure of two crossings, and safety enhancements to the two remaining crossings. These improvements create a sealed rail corridor, improve safety, reduce traffic congestion, and significantly reduce train horn noise.
- **Newark "East Bay" Intermodal Station:** In the vicinity of Newark Junction, a new multi-modal station is proposed. The station would include a park-and-ride facility and connections to potential Dumbarton bus rapid transit or commuter rail services under consideration by Caltrain. The location of the station is not yet determined.

## Newark to Oakland

- **Right-of-Way Acquisition:** This project creates a passenger only corridor between Newark and Oakland. Right-of-way requirements within this segment include acquisition of:
  - 19.5 miles of Coast Subdivision between Elmhurst Junction (MP 13.5) and Newark (MP 33.0);
  - 3 miles of the Oakland Subdivision between MP10.3 and MP13.3; and
  - 60-foot strip of the Niles Subdivision along the east edge of the East Oakland rail yard (MP 8.5 to MP 7.5) to the Lake Merritt Outlet.

- **Double Track Newark to Oakland:** The project constructs 19.5 miles of a new second main track between Newark and Elmhurst Junctions. The project also rehabilitates the existing main track and installs new concrete ties and rail.
- **Elevated Guideway along Oakland Subdivision:** The project creates 5 miles of elevated double-track guideway adjacent to BART on the Oakland Subdivision, and includes a rail grade separation over the UPRR Niles Subdivision and 1 mile of new double track along the East Oakland Yard from Elmhurst Junction to Lake Merritt Outlet.
- **Oakland Coliseum Intermodal Station:** The project constructs a new elevated passenger station adjacent to the BART station with cross platform connections to BART and the Airport Connector.
- **Grade Separations:** The project provides for the construction of 15 new grade separations and the closure of the five remaining crossings in this segment. This creates a sealed rail corridor, improves safety, reduces traffic congestion, and significantly reduces train horn noise.

## Jack London Square (JLS)

- **Jack London Square Tunnel and Underground Station:** The project constructs a cut-and-cover subway tunnel within the 2nd Street right-of-way between Lake Merritt Outlet and Market Street. The project envisions modifications to the upper section of the Posey and Webster tubes that allow the track to pass over the tubes at a lower elevation than without the modifications. A new underground Jack London Square Station between Washington and Franklin Streets is included as part of this project, including a potential connection with a future BART second bay tube crossing. An alternative design shifts the alignment into the block between Embarcadero and 2nd Street. Refer to Technical Appendix 3: “Jack London Square Alternatives Evaluation” for more information.

## Oakland to North Richmond

- **Right-of-Way Acquisition:** Within this segment a 35-foot to 45-foot strip of right-of-way between MP 6.0 (Niles) and MP 13.0 (Martinez) is acquired from the UPRR as well as limited 10-foot to 30-foot strips of adjoining property to create a shared rail corridor with separate freight and passenger tracks.
- **Oakland Yard Passenger Bypass:** The project constructs new freight main tracks adjacent to existing main tracks between the UPRR Desert and West Oakland Yards. The two existing UPRR main tracks are converted to passenger only use.
- **Double Track Oakland to North Richmond:** The project shifts the existing UP double track to the west side of the right-of-way and constructs a new passenger double track within the existing corridor.
- **Grade Separations:** The project constructs 6 new grade separations and proposes to close ten existing crossings through the cities of Emeryville, Berkley, and Richmond. This creates a sealed rail corridor, improves safety, reduces traffic congestion, and significantly reduces train horn noise.
- **Station Modifications:** The project modifies the Emeryville, Berkley, and Richmond stations to accommodate the new track alignment and center platform configurations.

## North Richmond to Benicia

- **Right-of-Way Acquisition:** Within this segment a 35-foot to 45-foot strip of right-of-way along BNSF and I-4 is acquired, including an easement for a 5.2-mile tunnel between Pinole and Martinez for the Franklin Canyon Bypass.
- **Franklin Canyon Bypass:** The project constructs 12.6 miles of new double-track passenger line paralleling BNSF/I-4, as well as a 5.2-mile twin-bore tunnel. The project also includes an Atlas Road grade separation and a potential new Hercules Station adjacent to an I-4 park-and-ride lot.
- **Carquinez Strait High Level Bridge:** The project constructs a new high-level double-track passenger bridge between Martinez and Benicia, including a segment of elevated guideway through Martinez within the existing right-of-way.
- **Martinez Station:** The project constructs a new elevated station at the existing station site as part of the elevated guideway through Martinez and includes a new parking structure.

## Benicia to Sacramento

- **Right-of-Way Acquisition:** Within this segment, the Project acquires the UPRR Martinez Subdivision from MP 34.2 to MP 89.0 for passenger-only service.
- **Rail and Tie Replacement:** The project upgrades the existing track to Class-7 track standards (125 mph) and includes the replacement of all timber crossties with concrete ties.
- **Grade Separations:** The project constructs 17 grade separations and proposes closing the seven remaining existing at-grade crossings to create a sealed rail corridor.
- **Station Modifications:** The project modifies the Suisun, Fairfield-Vacaville, and Davis stations to accommodate a new center platform design and level boarding.

## Sacramento to Roseville

- **Right-of-Way Acquisition:** Within this segment, a 45-foot to 60-foot strip of right-of-way between MP 91.0 and MP 106.4 on the Martinez Subdivision is acquired from the UPRR. Acquisition of 10-foot to 30-foot strips of property outside of the existing right-of-way are also required in limited areas in order to create a shared corridor.
- **New Third Main Track:** The project constructs a new third main track within UPRR right-of-way between Sacramento and Roseville that includes a crossing of the American River, improvements at Roseville Station, and a new layover facility in Roseville.
- **Second Passenger Main Track:** The project constructs a second passenger-only track between Sacramento and Roseville once the dedicated passenger right-of way is acquired. Once completed the corridor will have four main tracks (2-Passenger + 2-Freight) with space to add a third freight track.

## Roseville to Auburn

- **Right-of-Way Acquisition:** Within this segment, a 30-foot to 45-foot strip of right-of-way between MP 106.4 and MP 124.0 is acquired on the UPRR Roseville Subdivision westbound route. Acquisition of 10-foot to 30-foot strips of additional right-of-way will also be required in limited areas in order to create a shared corridor.
- **Passenger Main Track:** The project constructs a new passenger-only main track, including an elevated guideway over the Valley Subdivision in Roseville to create a shared rail corridor.

- **Grade Separations:** The project proposes to construct nine grade separations between Roseville and Auburn.
- **Station Modifications:** The project constructs a new elevated station in Roseville, modifies the existing Rocklin Station, and constructs a new at-grade station in Auburn to accommodate a new track and center platform configuration. Note that the change in grade between the passenger tracks over the Valley Subdivision results in the need for the Roseville station to be elevated or potentially relocated.

## Systemwide Improvements

- **Incremental Speed Increases:** The VIP proposes a series of smaller projects to incrementally increase passenger speeds to 90 mph between San Jose and Benicia and to 110 mph between Benicia and Sacramento prior to electrification. Speed improvements correspond to service improvements.
- **San Jose – Sacramento Electrification:** The project electrifies the corridor between San Jose and Sacramento to allow for 125 mph operations.
- **Purchase EMU Trainsets:** The project purchases 24 electric multiple unit (EMU) trainsets each capable of speeds of 125 mph or greater.
- **Station Platform Modifications:** The project modifies all existing platforms to provide for Systemwide level boarding.
- **CMOF:** Project constructs a new Control/Maintenance/Operations Facility (CMOF) to maintain high speed trainsets.



Table 1-1 Recommended Vision Capital Improvement Program

Service Area	Line Segment	Project	Lead Agency	Description	Purpose	Priority Justification
San Jose - Oakland	SJ-CPC	San Jose to Santa Clara Phase 3 & 4 Track Improvements	PCJPB/ CHSRA	Add 2.5 miles of new main track and reconfigure Diridon Station leads.	Provide increased capacity to serve expanded Caltrain, Capitol Corridor, and ACE services. Work partially funded by CCJPA.	Improvements partially funded by CCJPA
	CPC-NWK	Right-of-Way Acquisition	CCJPA/ACE	Acquire dedicated right-of-way including a 45'-60' strip between CP Coast (MP 44.6) and Great America, 60'-80' strip across the Alviso Salt Flats to Newark Junction (MP 31.0).	Provide a dedicated passenger only right-of-way.	Allows at least 15 round trips to San Jose; support ACE expansion plans
		Double Track CP Coast to Newark	CCJPA/ACE	Construct 14.5 miles of new double main track between CP Coast and Newark. Add center platform at Santa Clara Great American Station	Provide track capacity to support 15 minute service headways and to protect against sea level rise between San Jose and Oakland.	Allows at least 15 round trips to San Jose
		Grade Separations	CCJPA/ACTC/ACE	Construct 7 new grade separations	Long term program to improve safety and reduce traffic impacts caused by at-grade crossings.	Grouped as priority 2 project.
		Newark Intermodal Station	CCJPA/ACE	Construct new multi modal Station at Newark including connection to Dumbarton Bridge Crossing to Redwood City	Replaces Union City and Fremont Stations and provides for connection to future Caltrain service to Between Union City and Redwood City.	Required when service is shifted to Coast line.
	NWK-OAK	Right-of-Way Acquisition	CCJPA/ACTC	Acquire 19.5 miles of Coast Subdivision between Elmhurst Jct. (MP 13.5) and Newark (MP 33.0). Acquire 3 miles of the Oakland Subdivision between MP10.3 and MP13.3, and a 60-ft Strip of the Niles Subdivision along the east edge of the East Oakland rail yard (MP 8.5 to MP 7.5).	Provide a dedicated passenger only right-of-way.	Allows at least 15 round trips to San Jose; support ACE expansion plans
		Newark to Oakland Second Main	CCJPA	Construct 19.5 miles of new second main track between Newark and Elmhurst Junctions. Replace existing main track timber ties with new concrete ties between Newark and Oakland.	Provide track capacity to support 15 minute service headways between San Jose and Oakland.	Allows at least 15 round trips to San Jose; support ACE expansion plans
		Elevated Guideway along Oakland Subdivision	CCJPA	Construct 5 miles of elevated double track guideway on Oakland Subdivision adjacent to BART and 1 mile of new double track along the East Oakland Yard from Elmhurst Junction to Lake Merritt Outlet.	Eliminate at-grade crossing conflicts and improve intermodal connectivity at BART Coliseum Station.	Dependent on funding availability, can slip to priority 3 or 4.
		Grade Separations	City/CCJPA/ ACTC	Construct 15 grade separations	Long term program to improve safety and reduce traffic impacts caused by at-grade crossings.	Grouped as priority 2 project.
		Oakland Coliseum Intermodal Station	CCJPA	Construct new passenger Station adjacent to the BART Station including cross platform connections.	Improve modal connectivity.	Dependent on funding availability, can slip to priority 3 or 4.
		Oakland Subdivision Acquisition	ACTC	Acquire 10.7 miles of Oakland Subdivision from MP 13.3 to MP 24.0.	Provide right-of-way for Eastbay Greenway Trail and to reconnect neighborhoods	If funding is available can be advanced to priority 1 or 2.
	JLS	Jack London Square Tunnel and Underground Station	City of Oakland/ CCJPA	Construct subway tunnel between Lake Merritt Outlet and Market Street along 2nd Ave and new underground Jack London Station between Washington and Franklin Streets.	Provide track capacity to support 15 minute service headways. Improve safety and reduce traffic impacts caused by at-grade crossings.	If funding is available can be advanced to priority 2 or 3.

Table 1-2 Recommended Vision Capital Improvement Program (continued)

Service Area	Line Segment	Project	Lead Agency	Description	Purpose	Priority Justification
Oakland - Sacramento	OAK-RCH	Right-of-Way Acquisition	CCJPA	Acquire dedicated 45'-60' right-of-way between MP 6.0 (Niles) and MP 13.0 (Martinez). Acquisition of 10' to 30' strips of R/W is required in limited areas.	Provide a dedicated passenger only right-of-way.	Required to increase service between Richmond and Oakland, can be advanced if funding is available.
		Oakland Yard Passenger Bypass	Port/CCJPA	Construct separate freight tracks adjacent to existing main tracks between UPRR Desert and West Oakland Yards.	Eliminate conflicts between freight trains accessing the Port and passenger trains passing through.	
		Double Track Oakland to North Richmond	CCJPA	Shift existing UP double track and construct new passenger double within existing corridor.	Provide track capacity to support 15 minute service headways.	
		Grade Separations	City/CCJPA/ ACTC	Construct 6 grade separations	Long term program to improve safety and reduce traffic impacts caused by at-grade crossings.	Grouped as priority 3 project.
		Station Modifications	City/CCJPA	Modify Emeryville, Berkley, and Richmond stations to accommodate new track alignment and center platforms	Improve safety and modal connectivity, provide modern station amenities, and prepare for level boarding	Required to increase service between Richmond and Oakland, can be advanced if funding is available.
	RCH-BEN	BNSF Right-of-Way Acquisition	CCJPA	Acquire a 40'-50' strip of Right-of-Way along BNSF and I-4 in Franklyn Canyon. Acquire new easement for 5.2 mile tunnel.	Provide a dedicated passenger only right-of-way.	Required for dedicated passenger corridor between Richmond and Sacramento.
		Franklin Canyon Bypass	CCJPA/SJJPA	Construct new double track passenger line paralleling BNSF/I-4 including 5.2 mile twin bore tunnel. Grade separate Atlas Road.	Improve running times and protect against sea level rise.	
		Carquinez Strait High Level Bridge	CCJPA	Construct new high level double track passenger bridge between Martinez and Benicia including elevated guideway segment through the industrial area of Martinez.	Eliminate delays caused by navigation conflicts.	
		Martinez Station	City/CCJPA	Construct new elevated station at existing site.	Improve safety and modal connectivity, provide modern station amenities, and prepare for level boarding	
	BEN-SAC	Right-of-Way Acquisition	CCJPA	Acquire Martinez Subdivision from MP 34.2 to MP 89.0.	Provide a dedicated passenger only right-of-way.	Long term maintenance program with UPRR.
		Rail and Tie Upgrade	CCJPA	Upgrade existing track to CL-6 including replacing timber cross-ties with all concrete ties.	Improve track to make the corridor ready for 90, 110, and 150 mph operations	
		Grade Separation	City/CCJPA	Construct 17 grade separations and close the remaining existing at-grade crossings.	Provides grade separated corridor for 125 mph operations.	Grouped as priority 5 project must be completed prior to 125 mph operations
		Station Modifications	City/CCJPA	Modify Suisun and Davis stations to accommodate new center platforms	Improve safety and modal connectivity, provide modern station amenities, and prepare for level boarding	Required for new electric trainsets

Table 1-3 Recommended Vision Capital Improvement Program (continued)

Service Area	Line Segment	Project	Lead Agency	Description	Purpose	Priority Justification
Sacramento - Auburn	SAC-ROS	Right-of-Way Acquisition	CCJPA	Acquire dedicated 40'-60' right-of-way between MP 91.0 and MP 106.4. Acquisition of 10' to 30' strips of R/W is required in limited areas.	Provide a dedicated passenger only right-of-way.	
		Construct new third main track	CCJPA	Construct a new 3 <sup>rd</sup> main track within UPRR Right-of-Way between Sacramento and Roseville including new crossing of American River, Roseville Station Improvements, and layover facility	Provides 10 round trips to Roseville	CCJPA currently seeking funding to complete project
		Construct Second Passenger Main Track	CCJPA	Construct a second passenger only track within dedicated Right-of-Way	Provide track capacity to support increased service levels.	
	ROS-SAC	Right-of-Way Acquisition	CCJPA	Acquire dedicated 30'-45' strip of right-of-way between MP 106.4 and MP 124.0. Acquisition of 10' to 30' strips of R/W is required in limited areas.	Provide a dedicated passenger only right-of-way.	
		Passenger Main Track		Construct a new passenger only main track including an elevated guideway over the Valley Subdivision.	Provide track capacity to support increased service levels.	
		Grade Separations	City/CCJPA	Construct 9 grade separations	Long term program to improve safety and reduce traffic impacts caused by at-grade crossings.	Grouped as priority 6 project.
		Station Modifications	City/CCJPA	Construct new elevated station in Roseville, modify Rocklin Station and construct new at-grade station in Auburn to accommodate new track and platform configuration	Improve safety and modal connectivity, provide modern station amenities, and prepare for level boarding	
System Wide	Incremental Speed Increases	CCJPA/ACE/ SJJPA	Increase passenger speeds to 90 mph between San Jose and Benicia and to 110 mph between Benicia and Sacramento	Reduce travel times		
	San Jose – Sacramento Electrification	CCJPA	Electrify corridor between San Jose and Sacramento	To improve operations, service levels, and air quality		
	Purchase EMU Trainsets	CCJPA	Purchase 24 electric trainsets capable of 150 mph operation.	To improve operations, service levels, and air quality		
	Station Platform Modifications	City/CCJPA	Modify existing platforms to provide for level boarding	Improve safety and reduce dwell times at stations		
	CMOF	CCJPA	Construct new Control/Maintenance/Operations facility	Service new electric trainsets		

## Recommended Stations and Facilities Improvements

A crucial element of the VIP is a systematic upgrading of the existing station to modern passenger rail standards including wide center platforms, grade separated pedestrian access, and level boarding platform heights. The station improvements also include expanded bus intermodal facilities and parking structures. New stations are constructed in Newark, Oakland Coliseum, Jack London, Martinez, Roseville, Auburn, and potentially adjacent to Hwy 80/Hwy 4 in the City of Hercules. Table I-2 describes types of improvements and staging options under consideration.

Table 1-4 CCJPA VIP Station Improvements Matrix

Station	Type of Improvement	Construction Staging Options
San Jose – Diridon	Additional platforms for HSR Level Boarding Improvements	Caltrain/CHSRA to Determine
Santa Clara – University	Level Boarding Improvements	Caltrain/CHSRA to Determine
Santa Clara – Great America	New Center Platform Station	New Construction north of Existing Station adjacent to City Place Development
Newark (New)	New Center Platform Station	New Station Site to be Determined
Oakland – Coliseum	New Elevated Station adjacent to BART	Expanded Bart Station Site
Oakland – Jack London	New Underground Station	New Station Site, potential TOD
Emeryville	New Center Platform Station	Temporary Closure
Berkeley	New Center Platform Station	Temporary Closure
Richmond – BART	New Center Platform Station	Shift BART Station to East and then Construct New Center Platform on Offset Alignment from existing station
Hercules	New Station	New Station Site Adjacent to I-4 Park-n-Ride Lot
Martinez	New Elevated Station	Overhead Construction on Offset Alignment at Existing Site
Suisun/Fairfield	New Center Platform Station	Temporary Closure
Fairfield/Vacaville	New Center Platform Station	Temporary Closure
Davis	New Center Platform Station	Keep in Service During Construction
Sacramento	Level Boarding Improvements	Keep in Service During Construction
Roseville	New Elevated Station	Overhead Construction on Offset Alignment
Rocklin	New Center Platform Station	New Station Site
Auburn	New Center Platform Station	New Station Site

Station improvements will be implemented in a phased manner with center platform construction and related improvements occurring concurrently with track improvements in the segment. Converting the platform to level boarding occurs later when the corridor is fully separated from freight traffic and electrified.



Once the Capitol Corridor is operating electric trains, it will need a new maintenance facility designed specifically for the type of trainset acquired as well as an operations control center to dispatch the trains. The VIP identifies potential locations for the control center and maintenance facility including:

- Expanded Oakland facility
- Shared High Speed Rail facility in South Bay
- New facility in Yolo County

Train layover yards will also be required near the San Jose Diridon, Oakland Jack London, and Sacramento stations.

## 2 FREIGHT MITIGATION CONCEPTS

The creation of a passenger-only rail corridor will likely significantly impact the operations of the UPRR and to a lesser extent the BNSF. The VIP identifies potential mitigation projects that restore diminished freight capacity, create additional capacity, and improve operational efficiency to the extent practical. The impacts and proposed mitigation to UPRR and BNSF operations are described by service area below.

### SERVICE AREAS

#### San Jose to Oakland Service Area

Between Newark and Oakland, Capitol Corridor acquires the Coast Subdivision and a 3-mile section of the Oakland Subdivision north of Elmhurst Junction, significantly impacting UPRR's operations. Between San Jose and Newark, the VIP identifies impact mitigation that creates a freight-only main track with a passing siding located midway between San Jose and Newark. The estimated capacity of the line is between 24 and 28 trains per day.

North of Newark, freight service to existing shippers is maintained on the Coast Subdivision through a freight easement, but switching service is limited to nighttime operations. Through-service freight operations on the Coast Subdivision north of Newark are prohibited except in emergency situations.

To compensate for the loss of through freight capacity, the VIP recommends a double-track high-capacity freight corridor on the Niles/Oakland Subdivision between the Port of Oakland and Niles Junction. The capacity of this freight-only double mainline is estimated at 55 to 60 trains per day. Capacity improvements on the Oakland Subdivision between Niles Junction and Stockton, currently envisioned as part of Altamont Corridor Express (ACE) Forward service improvements, will increase the capacity of the line to 25 and 30 trains per day. See Figure 2-1 for locations of the proposed improvements.

#### Oakland to Sacramento Service Area

Once the CCJPA acquires Martinez Subdivision from Benicia (MP 34.2) to Sacramento (MP 89.0), the UPRR's primary freight route between the East Bay and its major classification yard in Roseville will be eliminated. There are currently 42 passenger trains and as many as 20 freight trains operating on the Martinez Subdivision north of Oakland daily. To compensate for the loss of through freight capacity, the VIP proposes a new double-track high-capacity freight corridor on portions of the former Sacramento Northern Railroad between Pittsburgh and West Sacramento (see Figure 2-2). The capacity of this freight-only corridor is estimated at 55 to 60 trains per day.

Figure 2-1 Freight Mitigation for San Jose to Oakland Service Area

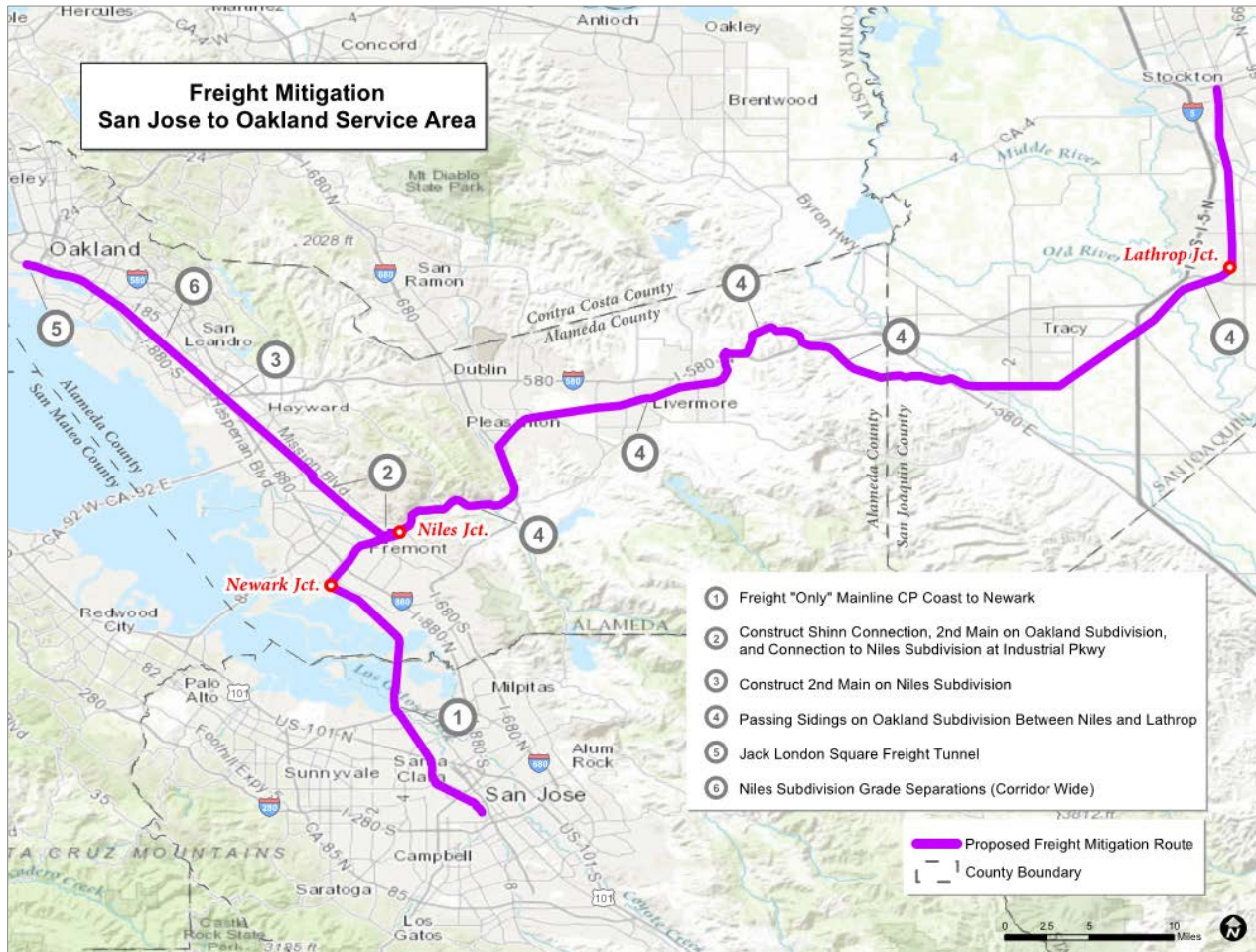
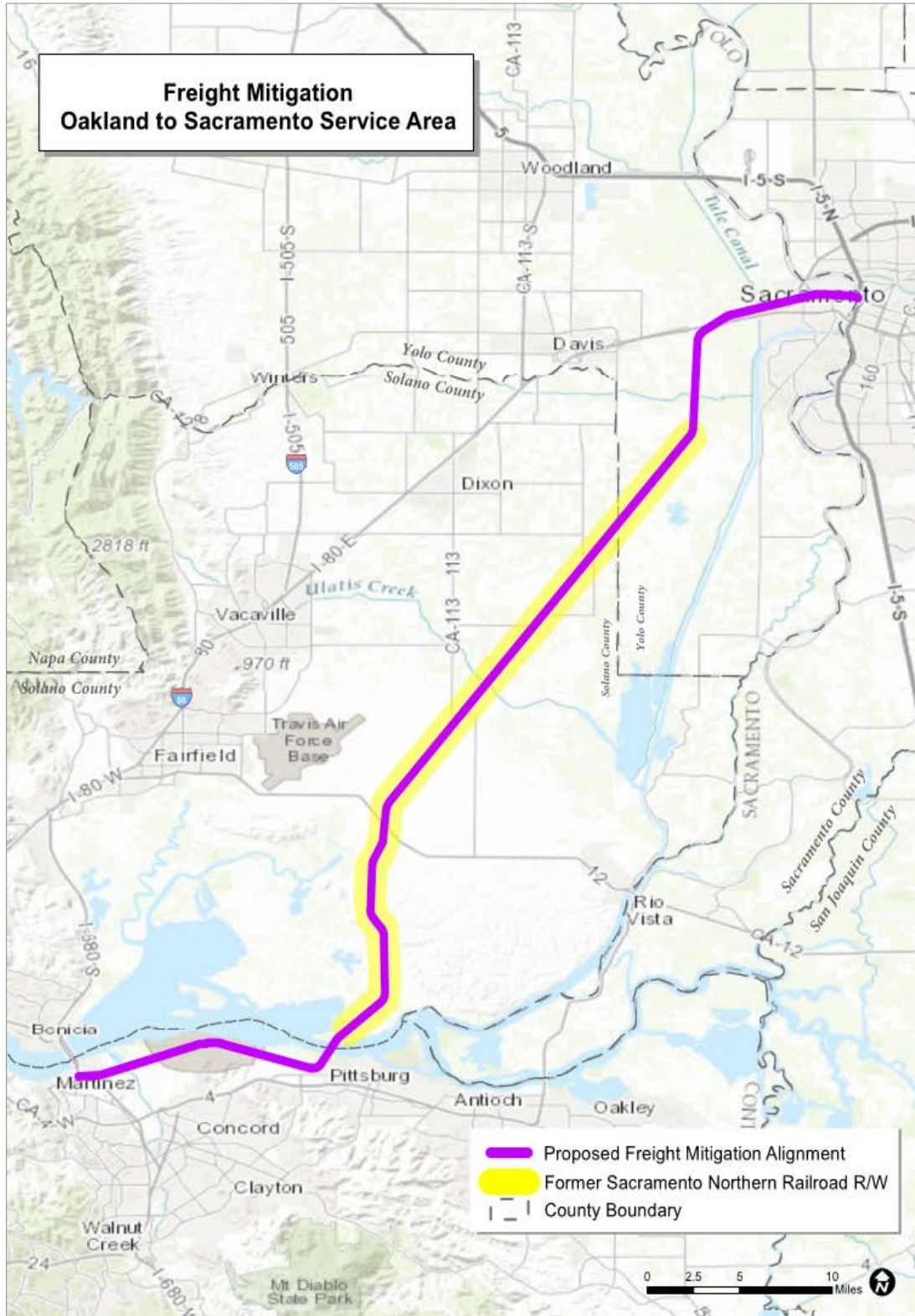

Figure 2-2: Freight Mitigation for Oakland to Sacramento Service Area





Freight service to existing shippers and California Northern Railroad's branch lines at Fairfield and Davis are maintained, but train service is limited to nighttime operations. Service to the petrochemical complexes and auto facility in Benicia continues to be provided by the existing railroad bridge across the Carquinez Strait from Martinez with no operating restrictions.

## Sacramento to Auburn Service Area

Between Sacramento and Roseville, the UPRR has an approximate 150-foot wide right-of-way with two main tracks. The Capitol Corridor operates on two new tracks on the northern 45 feet to 60 feet of the right-of-way leaving the existing two main tracks plus room for a future third main for freight trains. Between Roseville and Auburn, the UPRR has two separate lines for eastbound and westbound trains between Roseville and Auburn. The eastbound line has the more favorable ascending grades into the Sierra Foothills. The Capitol Corridor shares the steeper westbound line and operates on its own single track within the corridor leaving the existing main track for freight. The freight mitigation for this service area is limited to compensation for the property used by the Capitol Corridor.

## EVALUATION CRITERIA

### Service Criteria

The freight mitigation projects are designed to provide at a minimum:

- Safe and reliable operations;
- Expanded freight capacity for efficient goods movement well into the future;
- No interference with passenger operations;
- Improved access to Port of Oakland; and
- Environmentally sustainable operations.

### Design Criteria

Conceptual freight alignment plans were prepared based on the following design criteria:

- Freight design speeds up to 79 mph, operating speeds up to 60 mph;
- UPRR main track design criteria and standard plans; and
- AREMA Manual for Railway Engineering dated 2015.

## RECOMMENDED CAPITAL IMPROVEMENTS

In order to mitigate freight impacts created by the Vision Plan, a long-term program of freight capital improvements and right-of-way acquisitions was developed for the geographic segments identified previously. Corridor alignment drawings were prepared (see <http://www.capitolcorridor.org/vision-plan/> for corridor drawings) to verify the feasibility of the proposed improvements and identify potential right-of-way impacts. The drawings were based on available aerial images and are at an early conceptual design level (5%-10%). Table 2-1 summarizes the proposed improvements and the following is a brief description of the proposed improvements by geographic segment starting in San Jose heading east to Auburn.

## San Jose to Newark

- **Diridon Station to Newark Junction Single Track Freight Main:** Once the additional passenger-only tracks are constructed within this 16-mile segment, the existing main track is dedicated to freight traffic and dispatched by the UPRR.

## Newark to Oakland

- **Shinn Connection to Oakland/Niles Subdivision:** The project constructs a new eastbound and westbound connection from the Oakland Subdivision to the Niles Subdivision at Shinn, approximately 1 mile west of the existing Niles Junction. From Shinn north to Industrial Parkway in Carpenter, a new second main track is proposed on the Oakland Subdivision. At International Parkway, a new double-track flyover from the Oakland Subdivision connects back into the Niles Subdivision. North of Industrial Parkway, the Oakland Subdivision can be abandoned, and the Niles Subdivision from Industrial Parkway (MP 24.5) south to Niles Junction (MP 30.0) can be abandoned.
- **Double Track Industrial Parkway to Elmhurst Junction:** The project constructs 11 miles of a new second main track from Industrial Parkway (MP 24.5) north to Elmhurst Junction (MP 13.5) where the Coast Subdivision rejoins the Niles Subdivision.
- **Grade Separations:** Between Niles Junction and Oakland, nine new grade separations and improvements to eight existing at-grade crossings are proposed as mitigation for increased freight traffic.
- **Niles Junction to Stockton Siding Improvements:** This ACE-led project extends seven sidings on the Oakland Subdivision between Niles Junction and Stockton and constructs new wye connections at Lathrop and Stockton Junctions.

## Jack London Square (JLS)

- **Jack London Square Tunnel/Trench:** The project constructs a combination trench/tunnel within the Embarcadero right-of-way between Lake Merritt Outlet and Market Street. The project envisions modifications to the upper section of the Posey and Webster tubes to allow the freight tracks to cross over the tubes and still provide a 2,400-foot cut/cover tunnel between Alice and Clay Streets. An alternative design shifts the alignment into the block between Embarcadero and Second Street.

## Martinez to Sacramento

- **Right-of-Way Acquisition:** The project transfers approximately 35 miles of the former Sacramento Northern right-of-way between Bay Point and Saxon from Contra Costa, Solano, and Yolo Counties to the UPRR. Approximately 6.5 miles of new 100-foot right-of-way is acquired from private property owners from Saxon north to CP Swingle on the Martinez Subdivision east of Davis.
- **Double Main Track:** The project constructs approximately 10 miles of second main track from Martinez to Bay Point on the UPRR's Tracy Subdivision. From Bay Point, the project constructs 42 miles of new freight double main track northeast to Swingle, where the line connects back into the Martinez Subdivision. Freight and passenger track share the existing right-of-way to Sacramento. The project also includes a new high-level freight rail bridge crossing the Carquinez Strait at Bay Point.

- **Grade Separations:** The project proposes constructing a new I-80 overpass at Swingle and 28 new at-grade crossings, as well as the closure of six crossings.
- **Route Alternatives:** There are two existing rail corridors between Martinez and Sacramento (see Figure 2-3) that are potential alternatives to restoring the Sacramento Northern alignment.
  - **Option 1 UPRR Tracy Subdivision:** The Tracy Subdivision extends from Martinez (MP 34.8) southeast approximately 58.2 miles to Lathrop where it connects to the Fresno Subdivision at MP 81.4. From Lathrop, trains utilize the UPRR's Fresno Subdivision northward approximately 54 miles to Sacramento where the Fresno Subdivision rejoins the Martinez Subdivision at Elvas Junction (MP 38.6) east of the Sacramento Station. The Tracy and Fresno Subdivisions would be double- or triple-tracked with improved connections at Lathrop, Stockton, and Elvas Junctions. The route is approximately 60 miles longer than the Martinez Subdivision and 57 miles longer than the proposed Sacramento Northern alignment.
  - **Option 2 BNSF Stockton Subdivision:** This alternative route utilizes the BNSF's Stockton Subdivision from Bay Point east to Stockton Junction where it connects to the UPRR's Fresno Subdivision at MP 84.5. From Stockton, trains use the UPRR's Fresno Subdivision for approximately 46 miles to Sacramento to rejoin the Martinez Subdivision at Elvas Junction (MP 38.6) east of the Sacramento Station. The BNSF Stockton and UPRR Fresno Subdivisions would be double- or triple-tracked with improved connections at Stockton and Elvas Junctions. A joint track usage agreement between the railroads will need to be negotiated. The route is approximately 35 miles longer than the Martinez Subdivision and 32 miles longer than the proposed Sacramento Northern alignment.

Figure 2-3 Freight Mitigation Route Alternatives

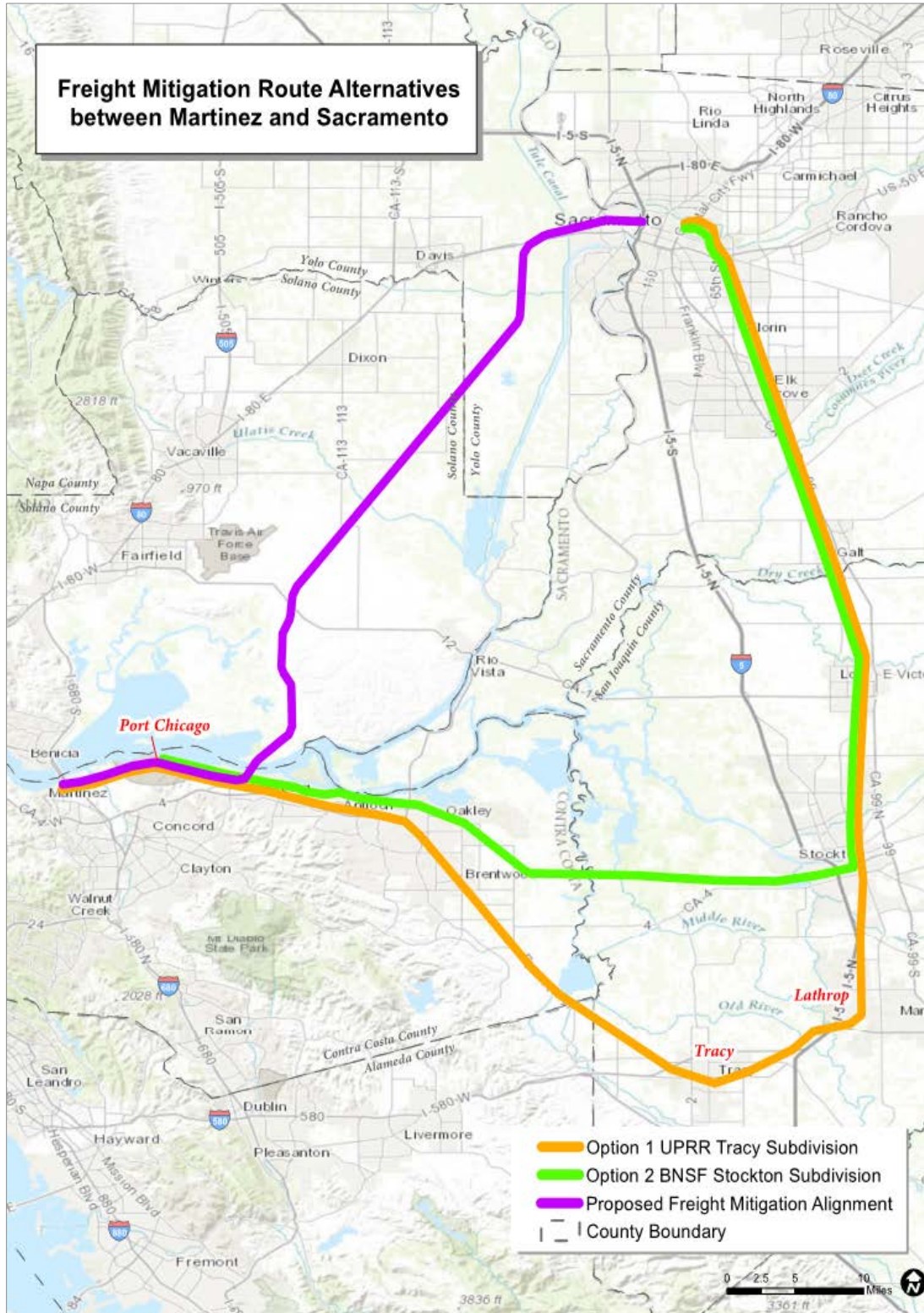

Table 2-1: Recommended Freight Mitigation Projects

	Line Segment	Project	Lead Agency	Description	Purpose	Priority Justification
Freight Mitigation	San Jose to Newark	San Jose to Newark Freight Main Track	CCJPA/Caltrain/ CHSRA	Converts the existing to freight only once passenger tracks are constructed	Replace lost freight capacity on Coast Subdivision south of Newark.	
	Newark to Oakland	Shinn Connection to Oakland/Niles Subdivision	CCJPA/ACE/ Port/ACTC	Construct new eastbound and westbound connections from the Oakland Subdivision to the Niles Subdivision at Shinn, near Niles Junction. Construct new 2nd main track from Niles Junction to Industrial Parkway on Oakland Subdivision and connect to Niles Subdivision at MP 24.5. Grade Separate Industrial Parkway. Abandon Niles Subdivision from MP 30.0 to MP 24.0	Replace lost freight capacity on Coast and Oakland Subdivisions by providing improved access to the Niles Subdivision from the Oakland and Coast Subdivisions.	If funding is available can be advanced to priority 2.
		Niles Double Track	CCJPA/ACE/ Port/ACTC	Construct 2nd main track between Oakland (MP 10.0) and Niles Junction (MP 24.5).	Replace lost freight capacity on Coast and Oakland Subdivisions by providing improved access to the Niles Subdivision from the Oakland and Coast Subdivisions	If funding is available can be advanced to priority 2.
		Grade Separation	CCJPA/ACE/ Port/ACTC	Construct 8 grade separations on Niles Subdivision	Improve safety and reduce traffic impacts caused by at-grade crossings.	Grouped as priority 3 project
		Niles Junction to Stockton Siding Improvements	ACE/Port	Extend 7 sidings and construct new Wye connections at Lathrop and Stockton.	Provide capacity for ACE service and increased freight service through Alameda County.	Required for ACE service increases. Costs not included in VIP estimates.
	JLS	Jack London Square Tunnel/Trench:		Construct a combination trench/tunnel within Embarcadero right-of-way between Lake Merritt Outlet and Market Street including modifications to the upper section of the Posey and Webster tubes and 2,400-ft cut/cover tunnel between Alice and Clay Streets. . An alternative design shifts the alignment into the block between Embarcadero and 2nd Street.	Project eliminates conflicts with pedestrians and vehicles	If funding is available can be advanced to priority 2 or 3.
	Martinez to Sacramento	Sacramento Northern Line Restoration	CCJPA	Construct new double track freight railroad between Bay Point and Sacramento along portions of former SNRR line.	Replaces capacity lost with sale of Martinez Subdivision.	



# 3 JACK LONDON SQUARE ALTERNATIVES EVALUATION

## BACKGROUND

Through the Jack London Square District of Oakland, the UPRR operates on a double main track line within the Embarcadero street right-of-way. The tracks connect UPRR's West and East Oakland rail yards and are the only southbound route (Niles Subdivision) out of the Port of Oakland for freight trains. The UPRR operates up to 18 freight trains a day through Jack London Square. The line also sees a significant amount of switching activity between the two rail yards. In addition to the freight traffic, Capitol Corridor, San Joaquin Corridor, and Amtrak operate 42 passenger trains a day across this 1.3-mile section of track to and from Jack London Square Station for a total of 60 trains per day.

In the previous Vision Plan update, a number of high-level concepts were developed for reconfiguring the tracks through Jack London Square. The concepts were further assessed, and new concepts developed, based on a site visit and informal charrette conducted with staff from the City of Oakland. The goal of this evaluation was to identify a design concept(s) based on the following:

- Engineering feasibility;
- Community impacts and political support;
- Capital costs (to be estimated on an order-of-magnitude basis);
- Operational impacts including travel time (to be estimated on a conceptual basis);
- Urban design impacts including pedestrian and bike access;
- Transit connectivity and access to major destinations; and
- Traffic impacts.

## ISSUES IDENTIFIED

The following issues were identified and discussed as part of the Charrette:

- Limited track capacity for future passenger and freight growth;
- Safety concerns due to increased conflicts between trains and pedestrian/vehicles;
- Infill development of condominiums and apartments creating increased demand for pedestrian access to the waterfront;
- Community's increased awareness of noise and vibration caused by the train traffic; and
- Under-realized value of waterfront development.

## ALTERNATIVES IDENTIFIED AND ELIMINATED FROM FURTHER CONSIDERATION

The following alternatives, as shown in Figure 3-1, were identified, evaluated by the study team as to their feasibility, and ultimately determined not feasible:

- **Additional At-grade Tracks:** While there is physical space to construct additional tracks within Embarcadero, the alternative was discarded because it does not address community concerns relating to safety, noise/vibration, traffic impacts, and access to waterfront.
- **Partially Depressed Alternative:** This alternative constructs a four-track trench within Embarcadero approximately 15 feet below street level. Cross streets are partially elevated (10 feet) above existing street level. The depth of the trench is restricted by the depth of the Webster and Posey tubes. The alternative was discarded because it does not address community concerns relating to safety, noise/vibration, and access to waterfront. Moreover, this alternative impacts a 106-inch EBMUD sanitary line located within Embarcadero and creates significant traffic and property impacts by raising the cross streets.
- **Fully Depressed Alternative:** This alternative would construct a four-track cut-and-cover tunnel within Embarcadero. This alternative was discarded because of impacts to the Webster and Posey tubes, utilities conflicts, constructability issues, and high capital costs.
- **I-880 Freeway Alternative:** This alternative relocates the existing freight tracks and add two passenger track adjacent to or in the median of I-880. The alternative was discarded because it did not meet the minimum geometric design criteria.
- **Long Tunnel Alternative:** This alternative constructs a twin bore tunnel diagonally across Oakland with a new station stop in the vicinity of the 19th Street Bart Station. The alternative was discarded because of high capital costs and it left the freight tracks at-grade within Embarcadero.

Figure 3-1: Jack London Square Alternatives Eliminated from Further Consideration

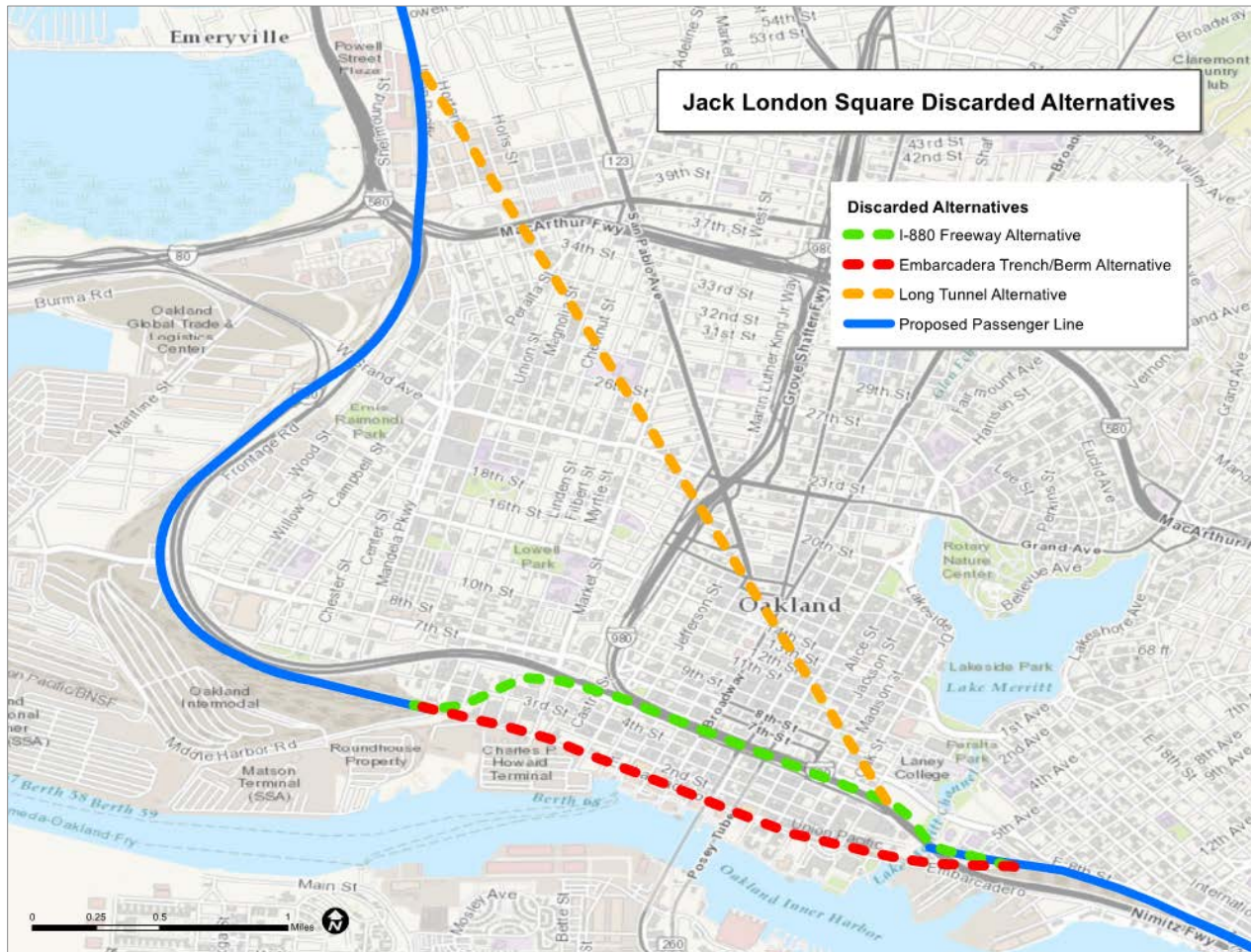

## RECOMMENDED FEASIBLE ALTERNATIVES

The following alternatives, as shown in Figures 3-2 and 3-3, were identified and determined to be feasible by the study team:

- **Paired Second St. and Embarcadero Alternative:** This alternative (see <http://www.capitolcorridor.org/vision-plan/> for corridor drawings) constructs a new passenger line primarily within the Second Street right-of-way from the Lake Merritt outfall north to Adeline Street. The passenger line is in a cut-and-cover tunnel between Oak Street and Market Street, except for a short segment of trench (1,000 feet) over the Webster and Posey Tubes. The upper portions of the tubes are modified (see Figure 3-4) to keep the track profile as low as possible. Franklin Street, Webster Street, Harrison Street, and Alice Street (extension) are raised from five and 13 feet to cross over the trench section. A new underground station with center platform configuration is constructed between Broadway and Jefferson Streets.

Once the Second Street alignment is complete, it will serve as a temporary freight bypass while a new cut-and-cover freight tunnel is constructed within the Embarcadero right-of-way. As in the Second Street alignment, the Webster and Posey Tubes are modified to keep the track profile as low as possible. Because the tubes are lower at Embarcadero, the freight line is completely



underground between Alice and Martin Luther King Streets. The section of Embarcadero over the tubes is raised three to five feet to provide adequate vertical clearance over the tracks.

- **Second St. and Embarcadero Mid-Block Alternative:** Similar to the paired alternative, this alternative (see <http://www.capitolcorridor.org/vision-plan/> for corridor drawings) constructs a new freight and passenger cut-and-cover tunnel immediately adjacent to the existing tracks. Both lines are constructed at the same time, minimizing disruptions to the community; however, this alternative requires significant property acquisitions. The acquired property is ultimately redeveloped as a Transit Oriented Development.

Figure 3-2: Paired Second Street and Embarcadero Alternative

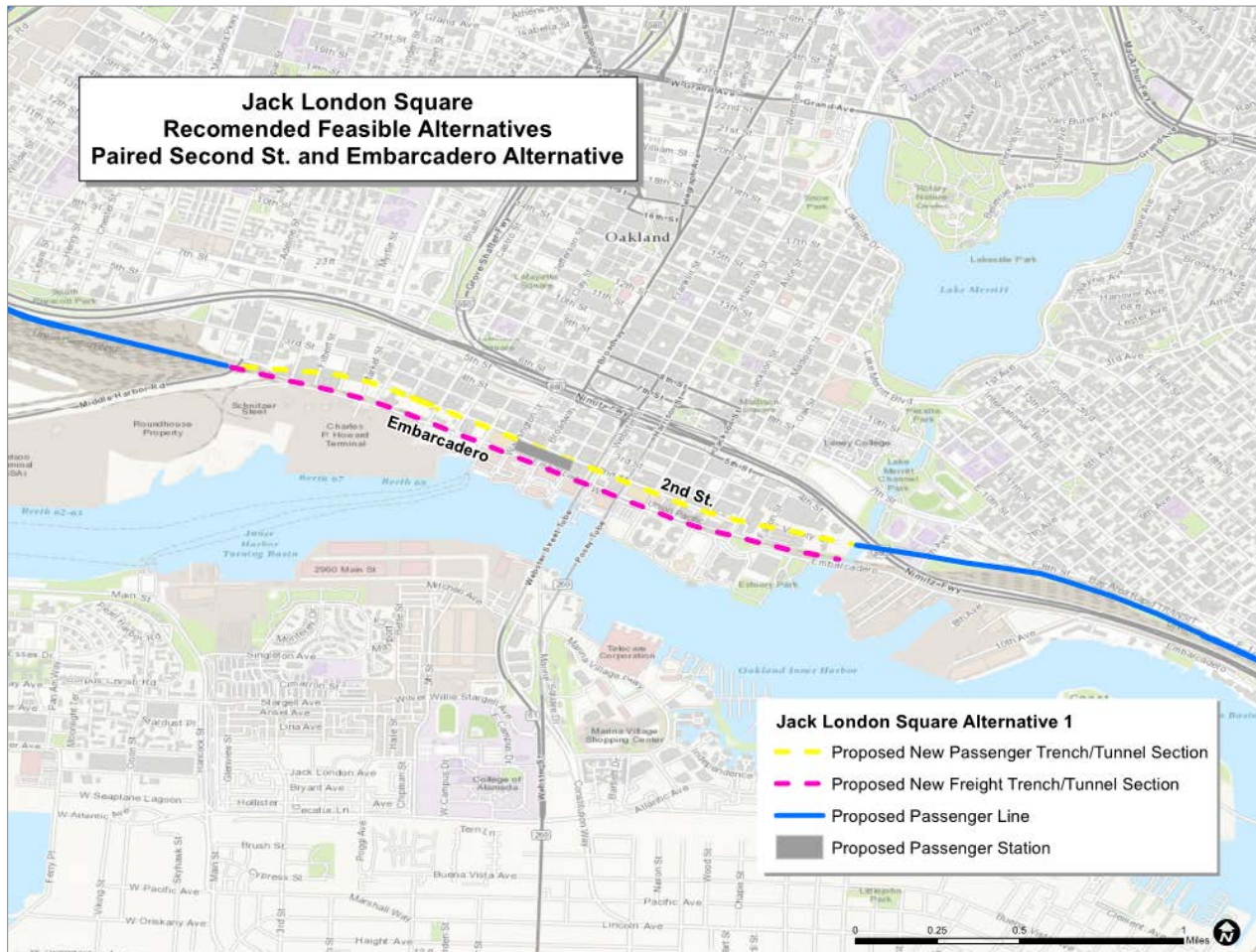

Figure 3-3 Second Street and Embarcadero Mid-Block Alternative

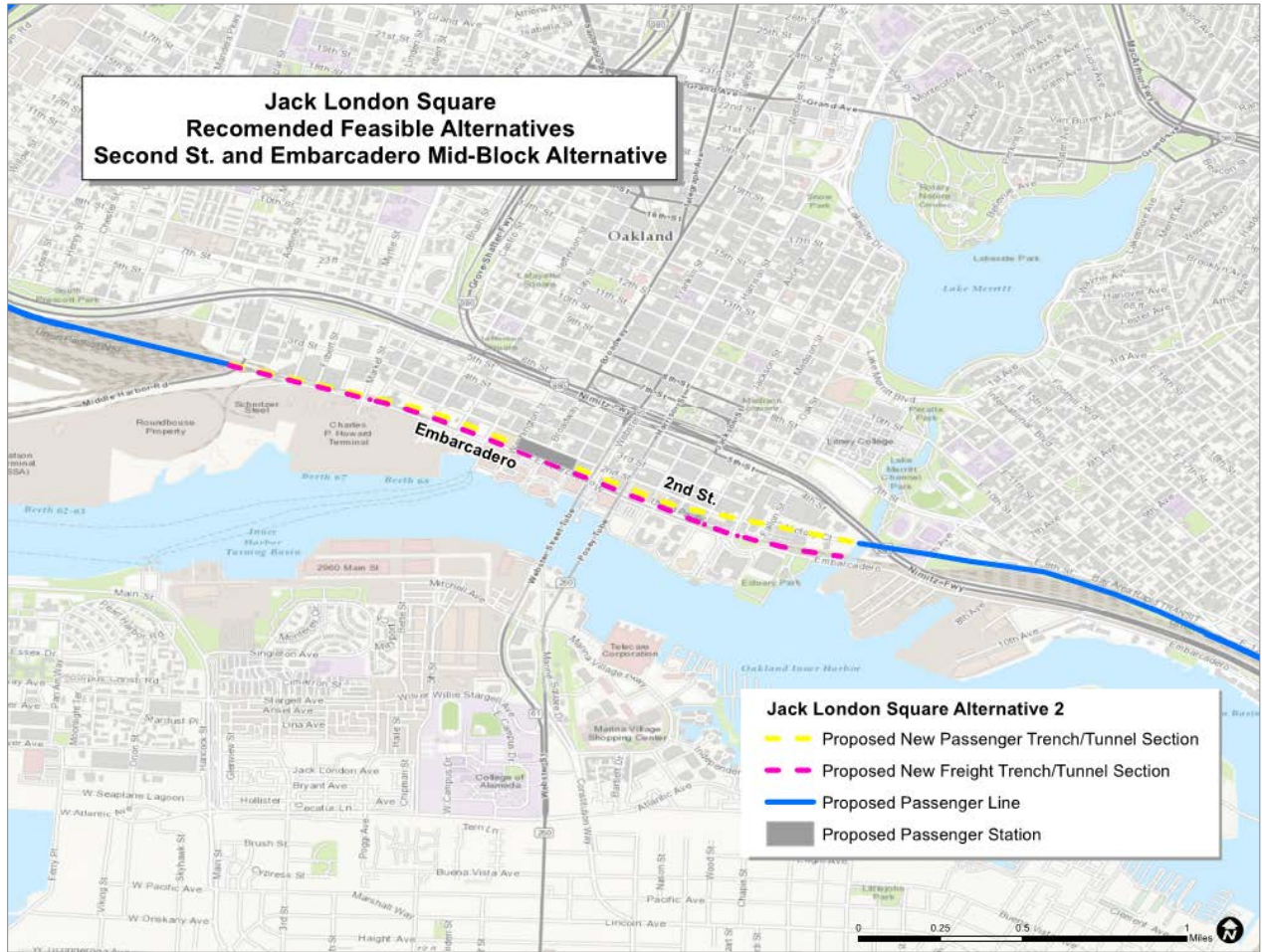
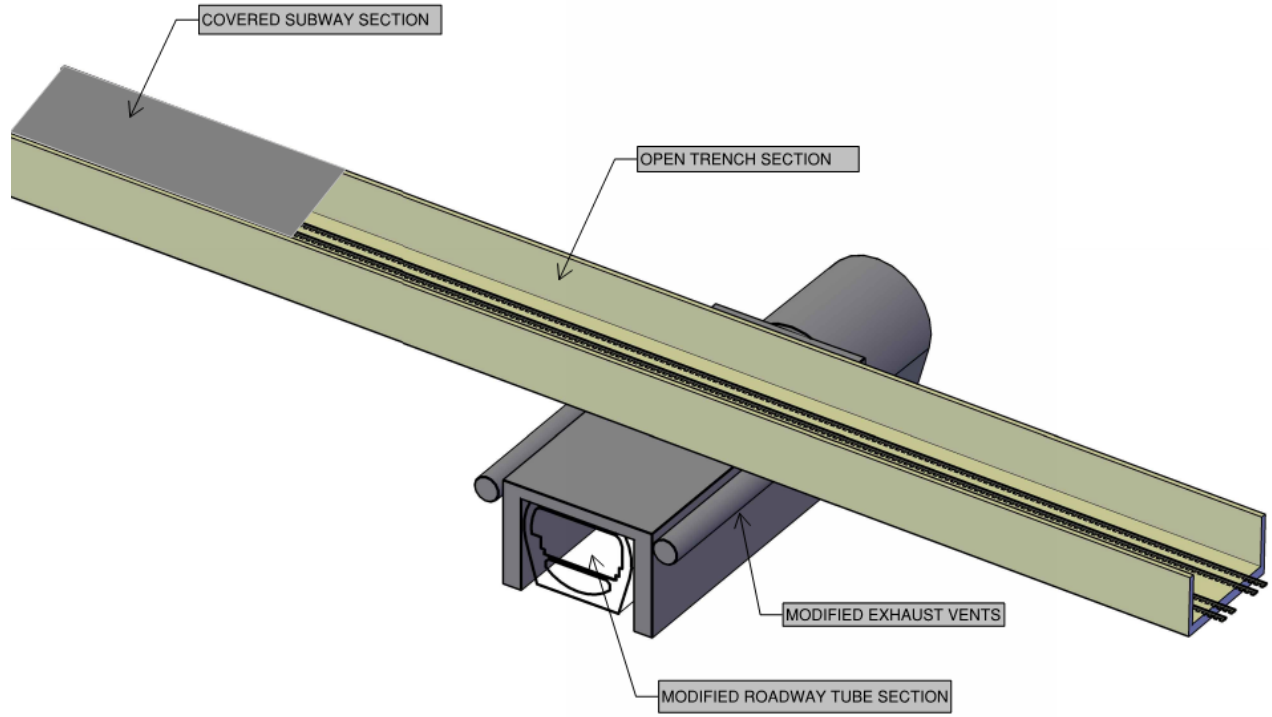



Figure 3-4 Proposed Modifications to the Webster and Posey Tubes



## 4 OPERATING PLAN, TRAVEL TIMES & OPERATING COSTS

The VIP was primarily a capital planning effort. However, in order to gain a sense of the implications for operating and maintenance costs of the capital plan, a conceptual operating plan was developed. In order to estimate operating costs, it was also necessary to estimate potential travel time improvements, with the understanding that any estimate at this point would likely be conservative, as future technology improvements are almost certain to result in greater time savings.

### OPERATING PLAN

Dedicated passenger right-of-way would allow for a dramatic increase in capacity – trains could theoretically operate as frequently as the train control system would allow, just minutes apart. This level of service, however, is unlikely to be needed in the corridor in the 21<sup>st</sup> Century. Pending findings of the demand and ridership analysis to occur in the VCP, it is likely that service levels in the mid-21<sup>st</sup> Century will need to be roughly equivalent to those operated today by Caltrain, or on individual BART lines, in order to meet demand. This would amount to a major increase in service over current levels.

For purposes of evaluation, the following conceptual operating plan was developed.

- There would be four trains per hours during the AM and PM peak periods.
- Two of these would be local/all-stop trains and two would be express/limited-stop trains. Headways would be 15 minutes at major station stops would be 15 minutes, and 30 minutes at secondary station stops.
- Mid-day and early evening service would consist of two local trains per hour, for a headway of 30 minutes.
- Late night, trains would operate hourly.
- Overall spans of service would extend from early morning until late night seven days a week (potentially from 5 a.m. to 11:30 p.m. at the departing terminals and 7:30 a.m. to 2 a.m. at the arriving terminals).
- Peak periods with 15-minute service (30-minute local plus 30-minute limited-stop service) would be from 6 a.m. to 9 a.m. and 4 p.m. to 7 p.m. Late-night service would begin around 9:30 p.m.

### Limited-Stop Service Pattern

The limited-stop service described above is assumed to include station stops at major locations including Sacramento, Davis, Martinez, Richmond, Oakland Jack London, Santa Clara Great America, and San Jose Diridon. Each of these is a major destination and/or transfer point.

## Short-Line Service

It would be possible, and might be desirable, to operate “short line” service within a segment of the corridor. The Capitol Corridor does this today, with more service between Sacramento and Oakland than between Oakland and San Jose, or Sacramento and Auburn. The above operating plan would apply between Sacramento and San Jose; there would likely be somewhat less service between Sacramento and Auburn, and between San Jose and Salinas if that segment were part of the corridor.

Conversely, there might be more service within the urbanized Bay Area, for example between Richmond and Oakland or Richmond and San Jose. This segment includes the major and growing employment and retail center of Emeryville, which is not connected to the BART system despite its inner-Bay Area location. “Infill” stations might also be added within this segment, for example at UC Berkeley’s Richmond Field Station. The additional service could be operated by the Capitol Corridor or another operator, such as BART; BART has studied the idea of providing its own service in this segment of the Capitol Corridor using diesel multiple unit or DMU trains like that it will soon operate on the “eBART” line in eastern Contra Costa County. Depending on decisions about the performance characteristics, the interlockings and platforms at Oakland-Jack London should be designed to allow an overlay train to hold while a Capital Corridor train passes.

## Trackwork Window

The proposed operating plan provides a three-hour window with no service anywhere in the corridor, and a five-hour window for trackwork on any one track between a designated pair of interlockings. Longer windows, up to seven hours, will be possible with single-track operation.

## TRAVEL TIMES

### Train Performance Analysis

An operational analysis was performed to help determine how different locomotive and train consist types (locomotives and cars) impact total schedule times with 79, 90, 110, 125, and 150 mph maximum track alignments, depending on constraints. The analysis looked at two operational scenarios:

- Interim service scenario that allows 110 mph operations (track geometry permitting) assuming shared operations with freight in all or part of the corridor.
- Full build service scenario that allows for up to 150 mph operations (track geometry permitting) assuming the line is separated from freight traffic and electrified.

### Train Performance Calculator

Train Performance Calculator (TPC) runs were performed using Rail Traffic Controller© (RTC) software developed by Berkeley Simulation Software, LLC. TPC runs calculate the estimated running time for a particular train consist over a specific segment of infrastructure, including the amount of time trains take accelerating and decelerating for station stops. TPCs are used to determine a train’s pure running time, one of three components used to develop schedules, as described below:

- **Pure Running Time:** The amount of time it takes a train to depart from one station and arrive at another.
- **Station Dwell Time:** The amount of time scheduled for a train at a station to allow for passenger entraining/detraining, crew changes, etc. Scheduled dwell times on the Capitol Corridor range from one to two minutes, depending on the typical passenger volume at a station.
- **Recovery Time:** Time that is added to a schedule to account for typical train delays, such as freight and passenger train interference, heavy passenger entraining or detraining, etc. Amtrak sets recovery time at 8 percent of the total pure running time.

### **Train Consist Selection**

For alignment options involving shared operations with freight service, only high speed diesel locomotive consists were tested, due to operational and infrastructure issues related to operating 150 mph electric high speed rail consists in shared corridors. The locomotive used in the calculations is the Motive Power Industries HSP-46 diesel locomotive, which is the only 125 mph-capable locomotive currently in revenue service in the United States. The new Siemens SC-44 Charger<sup>®</sup> diesel locomotive is currently undergoing revenue testing and will provide a better performing alternative to the HSP-46.

There are two existing 110 mph passenger train operations outside of the Northeast Corridor; sections of the Chicago-Detroit-Pontiac Wolverine Service route, and sections of the Chicago-St. Louis Lincoln Service route. In order to attain consistent 110 mph operation on the segments upgraded to support that speed, Amtrak utilizes two General Electric P-42 locomotives per train. On both routes, 110 mph segments are intermixed with lower speed segments, i.e., trains need to accelerate and decelerate constantly to attain maximum operating speed. With only one P-42 locomotive in the consist, the tractive effort of just one locomotive is insufficient to allow the trains to attain and maintain 110 mph operation for any significant amount of time before the trains need to slow for reduced speed segments.

### **Interim Service Scenario**

In order to evaluate performance with operating conditions similar to existing Amtrak 110 mph operations, the train performance analysis tested typical Capitol Corridor bi-level train consists with both one and two locomotives and improved track infrastructure and alignment alternatives capable of supporting 79, 90, and 110 mph maximum speeds.

The complete schedule times for all-stop train service between Sacramento and San Jose Diridon, for each locomotive and infrastructure alternative, are shown in Table 4-1 below:

Table 4-1 All-Stop Travel Times

Northbound	Current Schedule		79 mph	90 mph	110 mph
1 HSP-46 diesel locomotive	3:08		2:52	2:50	2:46
2 HSP-46 diesel locomotives	...		2:45	2:38	2:34

Southbound	Current Schedule	79 mph	90 mph	110 mph
1 HSP-46 diesel locomotive	3:08	2:50	2:47	2:44
2 HSP-46 diesel locomotives	...	2:41	2:34	2:31

The TPC results offer some interesting comparisons. For example, an eastbound train with one locomotive operating on the improved 110 mph alignment makes the run from Sacramento to San Jose Diridon in 2 hours and 46 minutes, compared to today's schedule of 3 hours and 8 minutes. For all alternative alignments, a two-locomotive consist performs significantly better than a one-locomotive consist, ranging from 7 minutes at 79 mph to 12 minutes at 110 mph. An eastbound train with two locomotives, operating over an improved 79 mph alignment, can make the same trip in 2 hours and 45 minutes, one minute faster than a one-locomotive consist operating on the 110 mph alignment. Figures 5-1 and 5-2 illustrate the maximum attainable speeds for the limited-stop and all-stop services using the two-locomotive consist. As the figures show, significant portions of the corridor between San Jose and Sacramento allows for trains to operate at speeds over 90 mph for both the all-stop and limited-stop schedules, primarily within the existing rail corridors.

Figure 4-1 Speed Chart - Two HSP46 Trainset, Northbound All-Stop Schedule

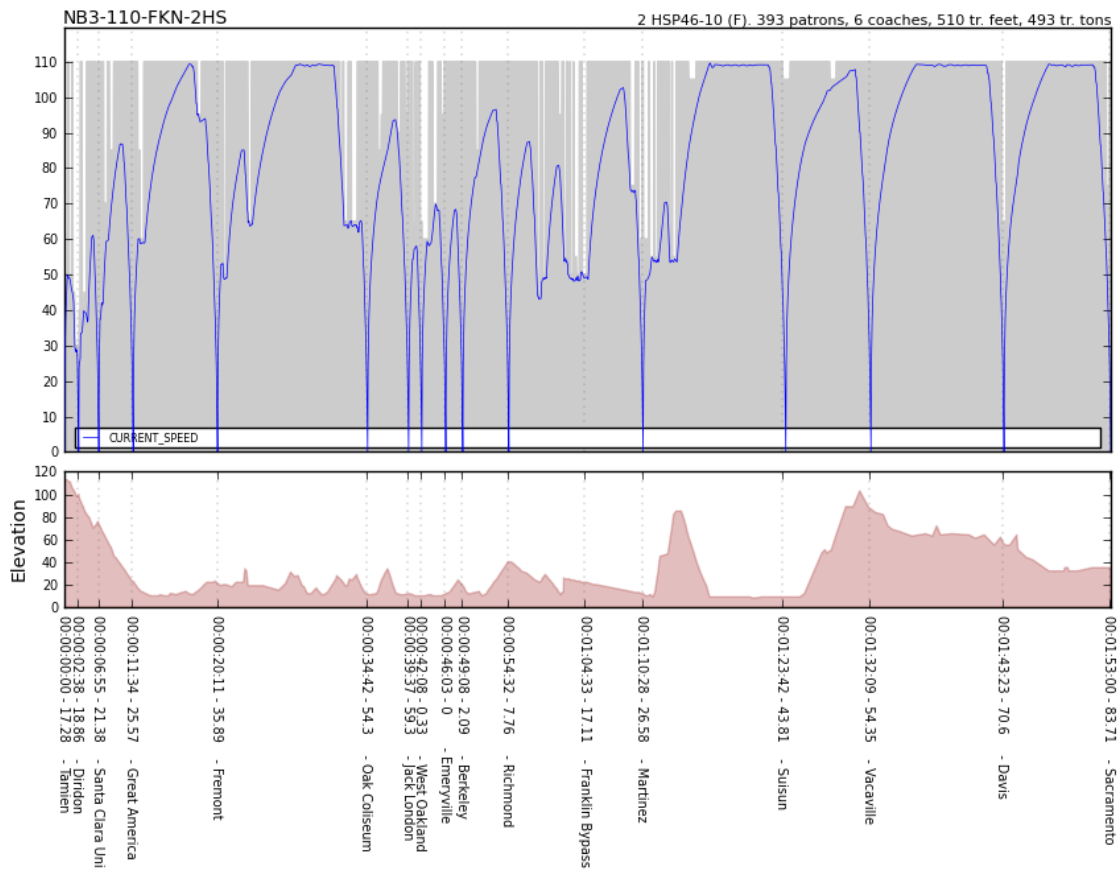
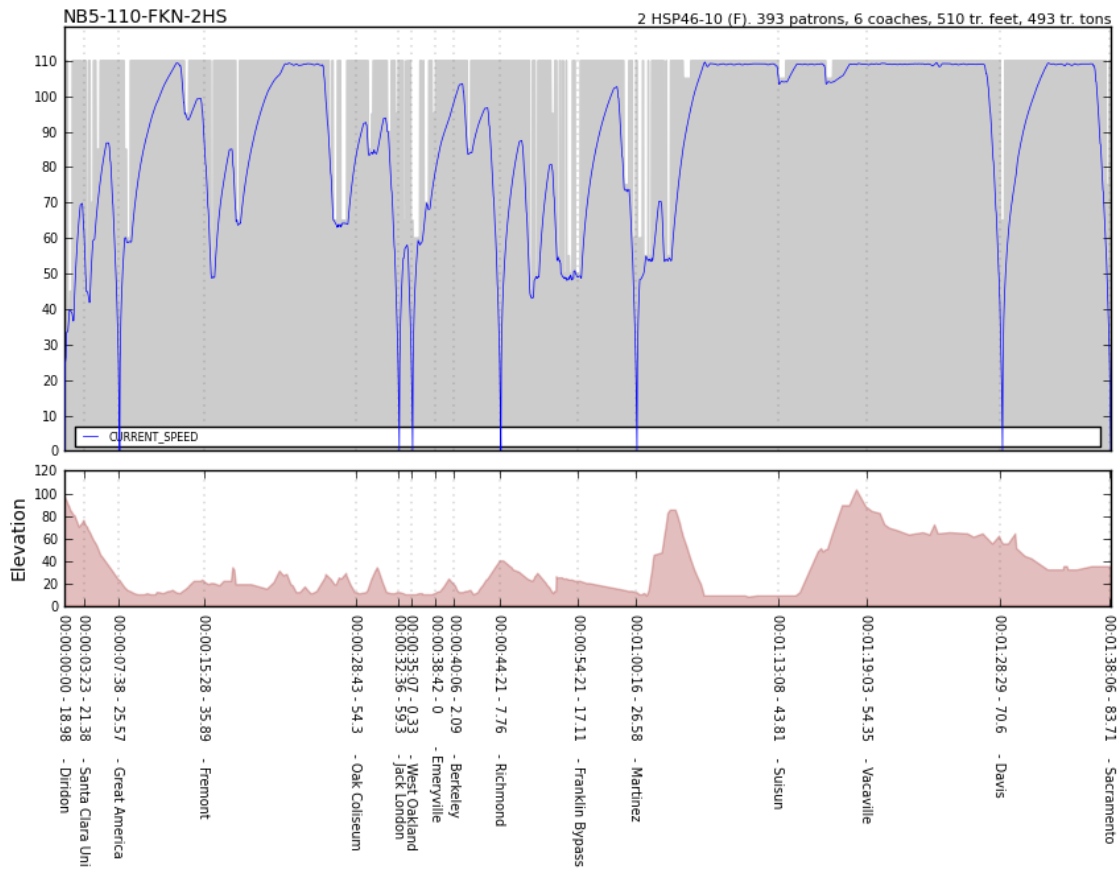



Figure 4-2 Speed Chart - Two HSP46 Trainset, Northbound Limited-Stop Schedule



The TPC results indicate that the same operating constraints in the 110 mph Midwestern routes also impact future Capitol Corridor operations. Due to speed restrictions imposed on all future alignment scenarios based upon geographical constraints, the segments capable of supporting higher maximum speeds are intermixed with segments mandating slower maximum speeds. A train consist capable of accelerating and decelerating rapidly is more able to maximize the amount of time that the train can attain maximum operating speeds.

Another major impact in corridors with shared freight and passenger operations involves the maximum operating speed differential between passenger and freight operations. In most shared passenger/freight corridors, maximum authorized speeds for freight trains vary between 40 and 60 mph, depending on the class of train, and up to 79 mph for passenger trains. Passenger trains operating at significantly faster speeds than freight trains consume a great amount of mainline capacity. Trains need to be spaced farther apart to avoid faster passenger trains “catching up” to slower freights operating in the same direction. Overtakes, where passenger trains pass freight trains at speed on the other main track, can take anywhere from 20 to 35 miles to accomplish, with a correspondingly high potential to delay opposing passenger and freight trains.

Based upon the TPC analysis the key findings for the interim service scenario are summarized as follows:

- Improved schedule times can be more effectively achieved by increasing the tractive effort for individual trains and minor geometric improvements within the existing rail corridors for speeds up to 110 mph.
- To obtain operating speeds greater than 110 mph on meaningful segments of the Capitol Corridor, extensive right-of-way acquisition and infrastructure improvements and the elimination of more station stops for express service would be required.
- Increasing maximum operating speeds beyond 79 mph on shared tracks requires significant capital funds for track and signal improvements, as well as potential right-of-way acquisition for flattening of select curves.
- Maintenance costs increase significantly for the higher classes of track required for 90 and 110 mph operation, as does the amount of time maintenance crews place tracks out of service to perform maintenance.
- Overall train capacity on a shared double main track decreases as the variance between passenger and freight train maximum operating speeds increases.
- Most capacity related improvements to the existing shared freight tracks to allow passenger trains to overtake slower freight trains corridor will not benefit passenger operations after transition to a dedicated passenger-only right of way is achieved.
- It is more cost effect to operate two-locomotive consists at 79mph then to build the additional track capacity required for 110 mph shared track operations. Speeds over 79mph should only be considered on dedicated passenger track segments.

### **Full Build Service Scenario**

The ultimate goal of the Capitol Corridor Vision Plan is to create a passenger-only rail corridor that:

- Operates without passenger/freight capacity and operational conflicts;
- Interlines with other regional electrified rail systems including Caltrain and High Speed Rail; and
- Utilizes electric propulsion technology to drastically reduce or eliminate greenhouse gas emissions.

TPC runs were conducted for the optimized 150 mph alignment using an Amtrak Acela train consist (2 power cars and 6 coaches), which currently operates at speeds of up to 165 mph on Amtrak’s Northeast Corridor. Table 5-2 below indicates the maximum speed attained by the Acela train consist by station-to station segment:

Table 4-2 Maximum Acela Consist Operating Speed by Segment

Train Schedule	Sacramento-Davis	Davis-Benicia	Davis-Vacaville	Vacaville-Suisun	Suisun-Benicia
Southbound Limited Stop					
Southbound All Stop	114 mph	120 mph	...	...	...
Northbound Limited Stop	114 mph	...	118 mph	117 mph	110 mph
Northbound All Stop	116 mph	121 mph	...	...	...

With an alignment primarily restricted to the existing rail corridors, TPC results show that there are no segments that permit 150 mph operation due to station spacing and geographical constraints. The only segment capable of permitting sustained speeds higher than 110 mph is the segment between Benicia and Sacramento.

As the table indicates, all sections of the Benicia-Sacramento segment allow for Acela train consist speeds to exceed Class 6 110 mph maximum speeds, but none allow for Acela to remotely approach the design speed goal of 150 mph. Only one section (southbound Davis- Benicia) allows the train to exceed 120 mph (121 mph).

Figures 4-3 and 4-4 illustrate the maximum attainable Acela train consist speeds and two HSP-46 train consist speeds for the limited stop services. As the figures indicate, the two HSP-46 train consist can operation at 125 mph over significant portions of the corridor between San Jose and Sacramento while the Acela can only achieve 120 mph for short period.

Figure 4-3 Speed Chart - Acela Trainset, Limited-Stop Schedule

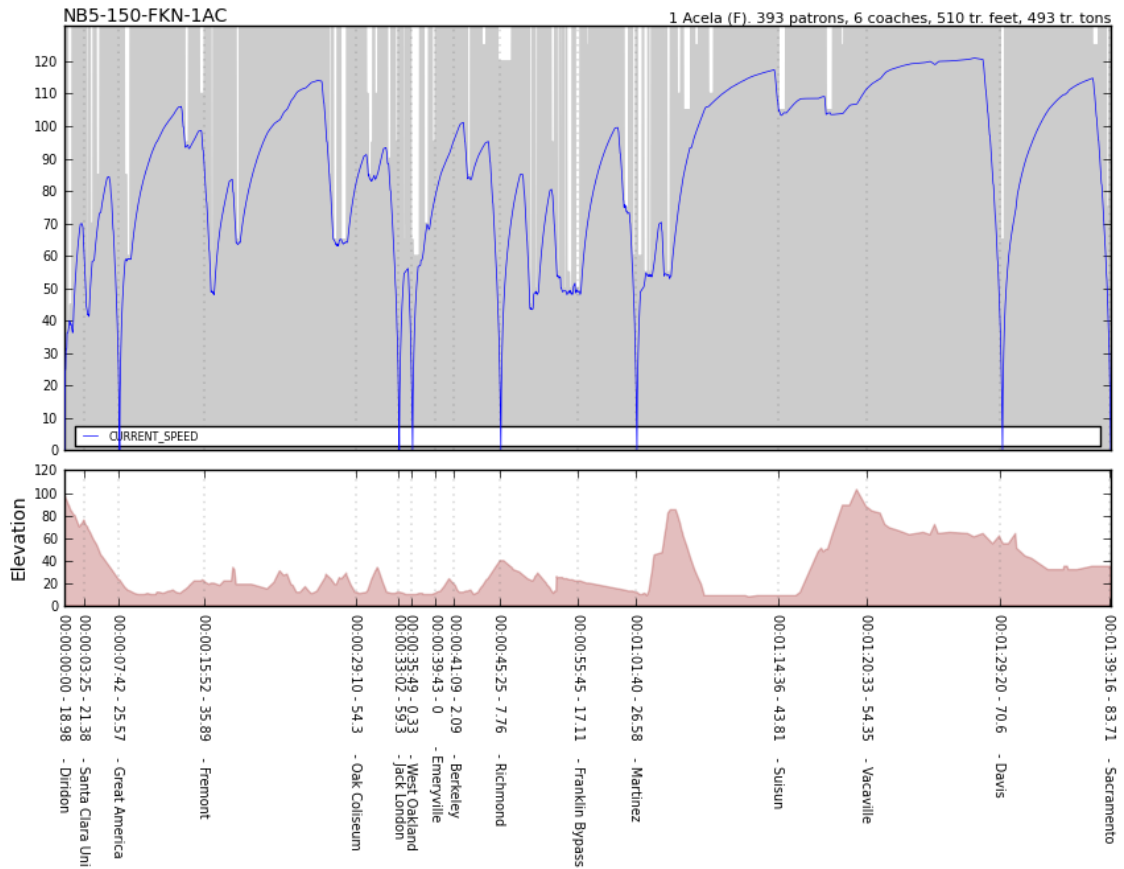

**Figure 4-4 Speed Chart - Two HSP 46 Trainset, Limited-Stop Schedule**

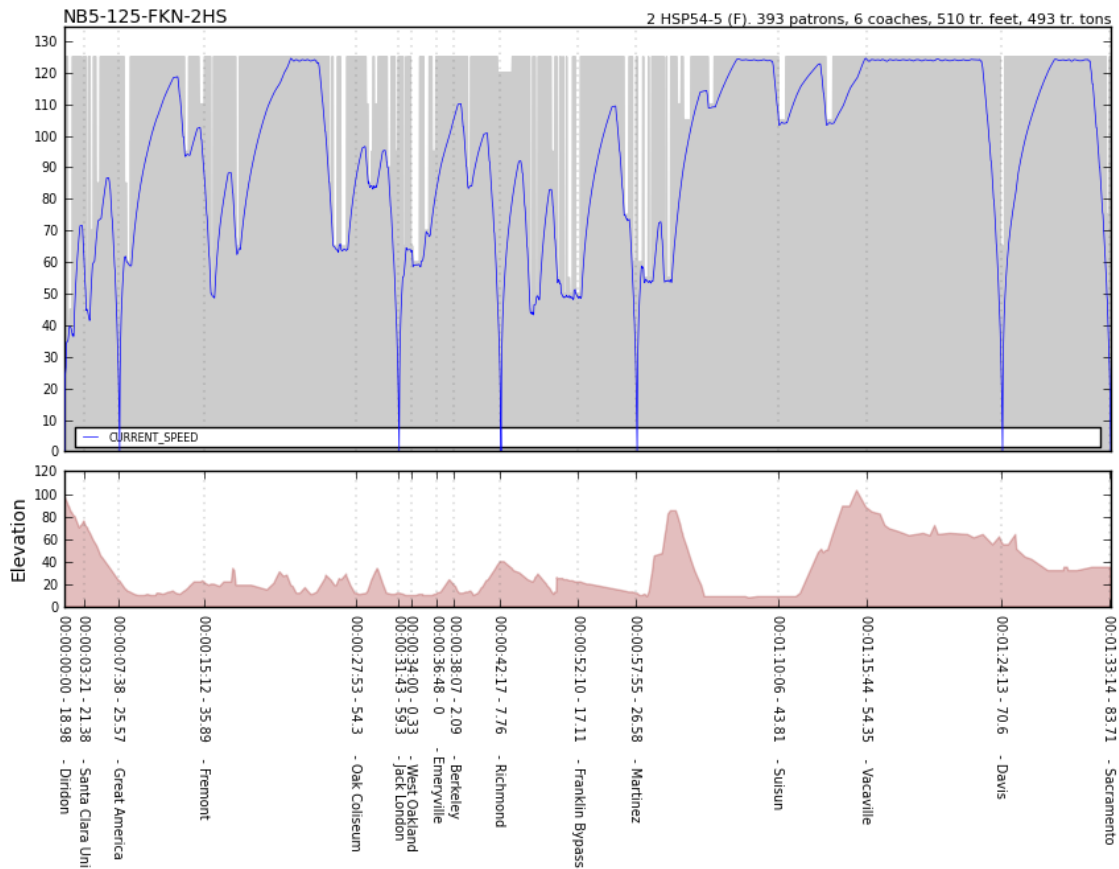

Table 4-3 below compares schedules developed for 150 mph capable electric service compared with schedules for 125 mph diesel trains powered by two locomotives:

**Table 4-3 Schedule Comparison - Acela Trainset and Two-Locomotive Diesel Consists**

All Stop	hh:mm	hh:mm
Eastbound	125	150
2 HSP-46 diesel locos	1:57	...
Acela trainset	...	2:06

Limited Stop	hh:mm	hh:mm
Eastbound	125	150
2 HSP-46 diesel locos	1:38	...
Acela trainset	...	1:53

According to the analysis, the two-locomotive diesel train consist, restricted to 125 mph maximum speed, outperforms the Acela train consist.

There is a marked difference in horsepower per ton of train consist (HPT) between the two-diesel locomotive and Acela train consists, according to the train consist profile generated by RTC:

- 2 HSP-46 locomotives, 6 bi-level cars: 14.13 HPT
- *Acela* (2 power cars, 6 coaches): 8.11 HPT
- Variance: 6.02 HPT

With significantly more power and tractive effort, the two-locomotive diesel train consist outperforms the Acela in its ability to accelerate from station stops and speed restrictions and therefore is able to support a shorter schedule than what the Acela can do.

It should be noted that Acela trains use electric propulsion technology that is over 20 years old. It is highly likely that trainsets eventually procured for the Capitol Corridor will have better performance characteristics, including acceleration and deceleration, than the Acela train consists used in the model (which is the only high speed electric train consists currently available for RTC). The procurement and eventual introduction of future state of the art electric trainsets will likely reduce pure running time for trains in the corridor by several minutes over the model's results for the two-locomotive diesel consist.

Based upon the TPC analysis, the key findings are summarized as follows:

- Projected schedule times for consists capable of 150 mph electric operations are slightly worse than 125 mph two locomotive diesel schedules, due to the diesel consists' higher horsepower per ton ratio. It must be reemphasized that newer electric rail technology will provide better acceleration/deceleration characteristics than is currently provided by Acela trainsets.
- Station spacing and geometric constraints limit the achievable operating speeds along the corridor as follows:
  - San Jose Diridon – Santa Clara Great America = 79 mph
  - Santa Clara Great America – Oakland Coliseum = 125 mph
  - Oakland Coliseum – Martinez = 110 mph
  - Martinez – Sacramento = 125mph
- Newer technology trainsets, however, may not provide enough of an improvement to justify planning for track segments at design speeds higher than 125 mph.

## TRAVEL TIMES

On the following pages are projected scheduled travel times between stations, including dwell time at stations (assumed to be one minute, except at Oakland Jack London Station, where 3 minutes, 30 seconds of dwell time is assumed in order to allow for schedule recovery).



Figure 4-5 Travel Times for All-Stop Service

	Sacramento	Davis	Vacaville	Suisun	Martinez	Richmond	Berkeley	Emeryville	Jack London	Oak Coliseum	Fremont	Great America	Santa Clara University	Diridon
Sacramento	0:00:00	0:08:58	0:20:28	0:29:22	0:43:35	1:00:23	1:06:45	1:10:40	1:19:36	1:25:39	1:40:36	1:49:41	1:55:16	2:00:05
Davis	0:08:58	0:00:00	0:11:30	0:20:24	0:34:37	0:51:25	0:57:47	1:01:42	1:10:38	1:16:41	1:31:38	1:40:43	1:46:18	1:51:07
Vacaville	0:20:28	0:11:30	0:00:00	0:08:54	0:23:07	0:39:55	0:46:17	0:50:12	0:59:08	1:05:11	1:20:08	1:29:13	1:34:48	1:39:37
Suisun	0:29:22	0:20:24	0:08:54	0:00:00	0:14:13	0:31:01	0:37:23	0:41:18	0:50:14	0:56:17	1:11:14	1:20:19	1:25:54	1:30:43
Martinez	0:43:35	0:34:37	0:23:07	0:14:13	0:00:00	0:16:48	0:23:10	0:27:05	0:36:01	0:42:04	0:57:01	1:06:06	1:11:41	1:16:30
Richmond	1:00:23	0:51:25	0:39:55	0:31:01	0:16:48	0:00:00	0:06:22	0:10:17	0:19:13	0:25:16	0:40:13	0:49:18	0:54:53	0:59:42
Berkeley	1:06:45	0:57:47	0:46:17	0:37:23	0:23:10	0:06:22	0:00:00	0:03:55	0:12:51	0:18:54	0:33:51	0:42:56	0:48:31	0:53:20
Emeryville	1:10:40	1:01:42	0:50:12	0:41:18	0:27:05	0:10:17	0:03:55	0:00:00	0:08:56	0:14:59	0:29:56	0:39:01	0:44:36	0:49:25
Jack London	1:19:36	1:10:38	0:59:08	0:50:14	0:36:01	0:19:13	0:12:51	0:08:56	0:00:00	0:06:03	0:21:00	0:30:05	0:35:40	0:40:29
Oak Coliseum	1:25:39	1:16:41	1:05:11	0:56:17	0:42:04	0:25:16	0:18:54	0:14:59	0:06:03	0:00:00	0:14:57	0:24:02	0:29:37	0:34:26
Fremont	1:40:36	1:31:38	1:20:08	1:11:14	0:57:01	0:40:13	0:33:51	0:29:56	0:21:00	0:14:57	0:00:00	0:09:05	0:14:40	0:19:29
Great America	1:49:41	1:40:43	1:29:13	1:20:19	1:06:06	0:49:18	0:42:56	0:39:01	0:30:05	0:24:02	0:09:05	0:00:00	0:05:35	0:10:24
Santa Clara University	1:55:16	1:46:18	1:34:48	1:25:54	1:11:41	0:54:53	0:48:31	0:44:36	0:35:40	0:29:37	0:14:40	0:05:35	0:00:00	0:04:49
Diridon	2:00:05	1:51:07	1:39:37	1:30:43	1:16:30	0:59:42	0:53:20	0:49:25	0:40:29	0:34:26	0:19:29	0:10:24	0:04:49	0:00:00

Figure 5-6 Travel Times for Limited-Stop Service

	Sacramento	Davis	Martinez	Richmond	Jack London	Great America	Diridon
Sacramento	0:00:00	0:08:58	0:36:39	0:53:27	1:07:22	1:32:31	1:41:10
Davis	0:08:58	0:00:00	0:36:39	0:44:29	0:58:24	1:23:33	1:32:12
Martinez	0:36:39	0:27:41	0:00:00	0:16:48	0:30:43	0:55:52	1:04:31
Richmond	0:53:27	0:44:29	0:16:48	0:00:00	0:13:55	0:39:04	0:47:43
Jack London	1:07:22	0:58:24	0:30:43	0:13:55	0:00:00	0:25:09	0:33:48
Great America	1:32:31	1:23:33	0:55:52	0:39:04	0:25:09	0:00:00	0:08:39
Diridon	1:41:10	1:32:12	1:04:31	0:47:43	0:33:48	0:08:39	0:00:00

## OPERATING COSTS

Crew requirements were used as a proxy for operating costs. Crew labor is usually the largest single cost driven by operations, and is generally proportional to car mileage, car maintenance, car inspection and track maintenance.

### Schedule Specifications

Sketch schedules were built with one minute dwell at intermediate stations, and three minute, 30 second dwell/recovery at Jack London Square. These dwells reflect high level platforms resembling a commuter operation. Terminal layovers for crews and consists are generally 25-30 minutes. Assuming CBTC, trains are kept temporally separated by 3 minutes running time.

### Crew and Train Requirements

Crew and train requirements were developed based on some experimentation with crew workday duration. The fleet size is 10 consists plus spares under the current headways, but with all trips extended to San Jose-Diridon, and the ultimate fleet size is 24 consists required for service, plus spares.

Crew requirements are currently 17 crews per weekday. The ultimate, recommended crew requirement is estimated to be 48 crews per weekday. In this crew schedule, most crews make one round trip, accruing about 5 hours 15 minutes cab time, meaning that with other allowances for reporting, inspecting and briefings, most crews will have at least an hour of time within the workday where they could be used for yard moves.

This reflects a decision, after study, to avoid both en route crew changes and exceptionally long workdays. In the context of Positive Train Control, daily briefings consume more time, a longer workday becomes untenable and en route crew changes cause longer dwell times.

We did, however, experiment with crew counts for longer workdays and en route crew changes.

- The crew requirement was 30 crews per weekday enforcing a maximum workday of 16 hours, with many split shifts.
- The crew requirement was 36 crews limiting the workday to 15 hours (with all longer jobs as split shifts) and a maximum workday of 12 hours for non-split shifts.
- We also tested workdays under 8 hours, but allowing an en route crew change at Oakland-Jack London, and produced a crew count of 40 crews.

These three crewing strategies create either very extreme workdays, where any lateness risks hours-of-service violations, or do not allow for enhanced crew briefings associated with Positive Train Control. The en route crew change required an extended dwell and recovery at Jack London Square and some risk of a stranded train if the relieving crew was late. These three strategies are not recommended.

As a result of not making en route crew changes, crew bases and yards, as well as running maintenance and inspection facilities, are needed at both Sacramento and San Jose-Diridon.

# 5 VISION IMPLEMENTATION STRATEGY

## PROJECT PRIORITIZATION

The VIP identified 37 individual projects or programs of improvements from right-of-way acquisition, to grade separations, to the purchase of new trainsets necessary to achieve the CCJPA vision of a modern electrified passenger line for Northern California. The VIP also identifies seven freight mitigation programs that are required to achieve the objectives of the Vision Plan. Once the 44 projects for the VIP and freight mitigations were identified they were prioritized based on the following general criteria:

- **Priority No.1:** Defined projects with environmental clearance and identified funding sources that can be implemented within the next 10 years.
- **Priority No. 2:** Projects that once implemented would significantly increase service and reduce travel times on portions of the Capitol Corridor. The projects require 10 to 15 years to implement since preliminary engineering and environmental analysis have not been initiated and funding sources have not been identified.
- **Priority No. 3:** Projects that are critical to achieving Capitol Corridor's vision of dedicated passenger rail system, but do not result in any significant interim service improvements. These projects require 15 to 20 years to implement.
- **Priority No. 4:** Large capital improvement projects that are critical to achieving Capitol Corridor's vision of dedicated passenger rail system, but also provide significant public benefits if implemented independently. These projects require 20 to 25 years to implement. If funding were secured, they could be implemented early.
- **Priority No. 5:** Large capital improvements projects that are required to achieving Capitol Corridor's vision of dedicated passenger rail system, but if implemented individually do not provide significant public benefits. These projects require 25 to 30 years to implement.
- **Priority No. 6:** Projects that extend electrified passenger service beyond the initial operating system envisioned between San Jose and Sacramento.
- **Priority No. 1-X:** Smaller projects that are part of a program of improvements, such as grade separations, that if implemented over a period of time provide cumulative public benefits up to the time the vision plan is fully implemented.

Table 5-1 Vision Project Priorities

Line Segment	Project	Purpose	Priority	Time Frame	Comments
San Jose to CP Coast	San Jose to Santa Clara Phase 3 & 4 Track Improvements	Provide increased capacity to serve expanded Caltrain, Capitol Corridor, and ACE services.	1	2020-2025	Improvements partially funded by CCJPA
CP Coast to Newark	Right-of-Way Acquisition	Provide a dedicated passenger only right-of-way.	2	2025 -2030	Allows 15 round trips to San Jose
	Double Track CP Coast to Newark	Provide track capacity to support 15 minute service headways and to protect against sea level rise between San Jose and Oakland.	2	2025 -2030	Allows 15 round trips to San Jose
	Grade Separations	Long term program to improve safety and reduce traffic impacts caused by at-grade crossings.	1-5	2020-2045	Grouped as priority 2 project.
	Newark Intermodal Station	Replaces Union City and Fremont Stations and provides for connection to future Caltrain service to Between Union City and Redwood City.	2	2025 -2030	Required when service is shifted to Coast line.
Newark to Oakland	Right-of-Way Acquisition	Provide a dedicated passenger only right-of-way.	2	2025-2030	Allows 15 round trips to San Jose
	Newark to Oakland Second Main	Provide track capacity to support 15 minute service headways between San Jose and Oakland.	2	2025-2030	Allows 15 round trips to San Jose
	Elevated Guideway along Oakland Subdivision	Eliminate at-grade crossing conflicts and improve intermodal connectivity at BART Coliseum Station.	2	2025-2030	Dependent on funding availability, can slip to priority 3 or 4.
	Grade Separations	Long term program to improve safety and reduce traffic impacts caused by at-grade crossings.	1-5	2020-2045	Grouped as priority 2 project.
	Oakland Coliseum Intermodal Station	Improve modal connectivity.	2	2025-2030	Dependent on funding availability, can slip to priority 3 or 4.
	Oakland Subdivision Acquisition	Provide right-of-way for Eastbay Greenway Trail and to reconnect neighborhoods	3	2030-2035	If funding is available can be advanced to priority 1 or 2.

Table 5-1 Vision Project Priorities (Continued)

Line Segment	Project	Purpose	Priority	Time Frame	Comments
JLS	Jack London Square Tunnel and Underground Station	Provide track capacity to support 15 minute service headways.	4	2035-2040	If funding is available can be advanced
Oakland to Richmond	Right-of-Way Acquisition	Provide a dedicated passenger only right-of-way.	3	2030-2035	Required to increase service between Richmond and Oakland. If funding is available can be advanced to priority 2
	Oakland Yard Passenger Bypass	Eliminate conflicts between freight trains accessing the Port and passenger trains passing through.	3	2030-2035	
	Double Track Oakland to North Richmond	Provide track capacity to support 15 minute service headways.	3	2030-2035	
	Grade Separations	Long term program to improve safety and reduce traffic impacts caused by at-grade crossings.	1-5	2020-2045	Grouped as priority 3 project.
	Station Modifications	Improve safety and modal connectivity, provide modern station amenities, and prepare for level boarding	3	2030-2035	Can be advanced if funding is available.
Richmond to Benicia	BNSF Right-of-Way Acquisition	Provide a dedicated passenger only right-of-way.	5	2040-2045	Required for dedicated passenger corridor between Richmond and Sacramento.
	Franklin Canyon Bypass	Improve running times and protect against sea level rise.	5	2040-2045	
	Carquinez Strait High Level Bridge	Eliminate delays caused by navigation conflicts.	5	2040-2045	
	Martinez Station	Improve safety and modal connectivity, provide modern station amenities, and prepare for level boarding	5	2040-2045	
Benicia to Sacramento	Right-of-Way Acquisition	Provide a dedicated passenger only right-of-way.	5	2040-2045	
	Rail and Tie Upgrade	Improve track to make the corridor ready for 90, 110, and 150 mph operations	2-3	2025-2035	Long term maintenance program with UPRR.
	Grade Separation	Provides grade separated corridor that is required for 150 mph operations.	1-5	2020-2045	Must be completed prior to 125mph operations
	Station Modifications	Improve safety and modal connectivity, provide modern station amenities, and prepare for level boarding	5	2040-2045	Required for new electric trainsets



Table 5-1 Vision Project Priorities (Continued)

Line Segment	Project	Purpose	Priority	Time Frame	Comments
Sacramento to Roseville	Right-of-Way Acquisition	Provide a dedicated passenger only right-of-way.	6	2045+	
	Construct new third main track	Provides 10 round trips to Roseville	1	2020-2025	CCJPA currently seeking funding to complete project
	Construct Second Passenger Main Track	Provide track capacity to support increased service levels.	6	2045+	Limited service expansion s possible without new main track.
Roseville to Auburn	Right-of-Way Acquisition	Provide a dedicated passenger only right-of-way.	6	2045+	
	Passenger Main Track	Provide track capacity to support increased service levels.	6	2045+	
	Grade Separations	Long term program to improve safety and reduce traffic impacts caused by at-grade crossings.	1-5	2020-2045	Grouped as priority 6 project in cost estimate.
	Station Modifications	Improve safety and modal connectivity, provide modern station amenities, and prepare for level boarding	6	2045+	
System Wide	Incremental Speed Increases	Reduce travel times	3-5	2030-2040	
	San Jose – Sacramento Electrification	To improve operations, service levels, and air quality	5	2040-2045	Could be deferred to priority 6 if 2 locomotive consist are used.
	Purchase EMU Trainsets	To improve operations, service levels, and air quality	5	2040-2045	
	Station Platform Modifications	Improve safety and reduce dwell times at stations	5	2040-2045	
	CMOF	Service new electric trainsets	5	2040-2045	

Table 5-2 Freight Mitigation Project Priorities

Line Segment	Project	Purpose	Priority	Time Frame	Comments
San Jose to Newark	San Jose to Newark Freight Main Track	Replace lost freight capacity on Coast Subdivision south of Newark.	2	2025-2030	Required to increase service to San Jose
Newark to Oakland	Shinn Connection to Oakland/Niles Subdivision	Replace lost freight capacity on Coast and Oakland Subdivisions by providing improved access to the Niles Subdivision from the Oakland and Coast Subdivisions.	2	2025-2030	Required to increase service to San Jose and shift freight off of Coast Subdivision.
	Niles Double Track	Replace lost freight capacity on Coast and Oakland Subdivisions by providing improved access to the Niles Subdivision from the Oakland and Coast Subdivisions	3	2030-2035	If funding is available can be advanced to priority 2.
	Grade Separation	Improve safety and reduce traffic impacts caused by at-grade crossings.	1-4	2020-2040	Grouped as priority 3 project in cost estimate
	Niles Junction to Stockton Siding Improvements	Provide capacity for ACE service and increased freight service through Alameda County.	1-2	2015-2030	Required for ACE service increases. Costs not included in VIP estimates.
JLS	Jack London Square Tunnel/Trench:	Project eliminates conflicts with pedestrians and vehicles	4	2035-2040	If funding is available can be advanced to priority 2 or 3.
Martinez to Sacramento	Sacramento Northern Line Restoration	Replaces capacity lost with sale of Martinez Subdivision.	5	2040-2045	Required for passenger only corridor between Martinez and Sacramento.

## IMPLEMENTATION PHASING STRATEGY

Once the projects were prioritized, they were grouped into four phases based on the potential to increase service levels and reduce travel time as follows:

- **Phase 1:** On-going projects that are programmed and have identified funding sources. Projects are implementable over the next 10 years and will provide modest service increases or travel time reductions.
- **Phase 2:** Mid-range projects providing significant increases in service and are achievable within the next 10 to 20 years, pending available funding.
- **Phase 3:** Long-range capital-intense projects that are required to achieve the vision, but require significant time to plan and implement. This phase will likely require 20 to 30 years to plan, fund, and implement.
- **Phase 4:** Expansion of electrified service beyond the San Jose to Sacramento Initial Operating Segment (IOS). This phase occurs after passenger-only operations are established on the IOS.

The implementation phasing strategy presents a first cut of the timeline of projects (see Table 5-3) that will allow significant increases in service levels.

Table 5-3 Implementation Timeline

	Time Frame	Projects
Phase 1	2016-2025	Priority 1
Phase 2	2025-2035	Priority 2 & 3
Phase 3	2035-2045	Priority 4 & 5
Phase 4	Beyond 2045	Priority 6

The timing of construction of each improvement is highly dependent on funding sources already committed, reasonably anticipated, or as yet unidentified. The phasing plan should be viewed as an ever-evolving process subject to further analysis and modification. It should be reviewed and updated every five years or as events warrant.

## PROJECT COSTS

Order-of-magnitude cost estimates were prepared for the identified program of improvements and right-of-way acquisitions and were grouped together based on their assigned priority (see Tables V-1 and V-2 for project priority). Unit costs were developed for the major construction items and order-of-magnitude quantities were developed for each group of projects based on priority.

Costs include basic construction costs in 2016 plus 21% for program management, engineering, environmental, and construction inspection. A 30% contingency was added to the base construction costs and program costs. The costs were escalated to the mid-point of construction based on a 3.0% annual inflation factor. Refer to Appendix VI for detailed order-of-magnitude costs and quantity estimates. It is important to note that most of the projects are in the very early stages of development and the project costs are subject to change as the projects are refined and economic conditions change.

Table 5-4 summarizes the costs based on the phasing criteria present in Table 5-3. Phase 1 costs are for the proposed third main track between Sacramento and Roseville that increases service from one round trip to ten round trips a day between Sacramento and Roseville.

Table 5-4 Project Costs (in 2016 Dollars)

Phase	Priority	Description	Time Frame	Project Cost
1	1	Sacramento-Roseville 3 <sup>rd</sup> Track	2016-2025	\$235M
2a	2	San Jose-Oakland Dedicated Passenger Corridor	2025-2030	\$3.78B
2b	3	Oakland-Richmond Dedicated Passenger Corridor	2030-2035	\$1.85B
3a	4	Jack London Square Tunnel	2035-2040	\$1.20B
3b	5	Richmond-Sacramento Dedicated Passenger Corridor	2040-2045	\$9.00B
4	6	Sacramento-Auburn Dedicated Passenger Corridor	Beyond 2045	\$2.13B

Figures 5-1 and 5-2 summarize the major cost components of Phase 2 (2a and 2b) of the implementation plan in 2016 dollars.

The estimated cost to create a dedicated passenger corridor between San Jose and Oakland is approximately \$3.78 billion. Completion of Phase 2a allows CCJPA to increase service from seven to 15 round trips daily between San Jose and Diridon, provides increased capacity for ACE trains, creates a high-capacity freight corridor from the Port of Oakland southward, grade separates the passenger corridor, and provides connectivity to the future Dumbarton rail crossing.

Extending the dedicated passenger corridor northward to Richmond is estimated to cost an additional \$1.85 Billion. Completion of Phase 2b allows CCPJA to run a shuttle service between Richmond and San Jose potentially using Diesel Multiple Units (DMU).

Figure 5-1 San Jose-Oakland Dedicated Passenger Corridor

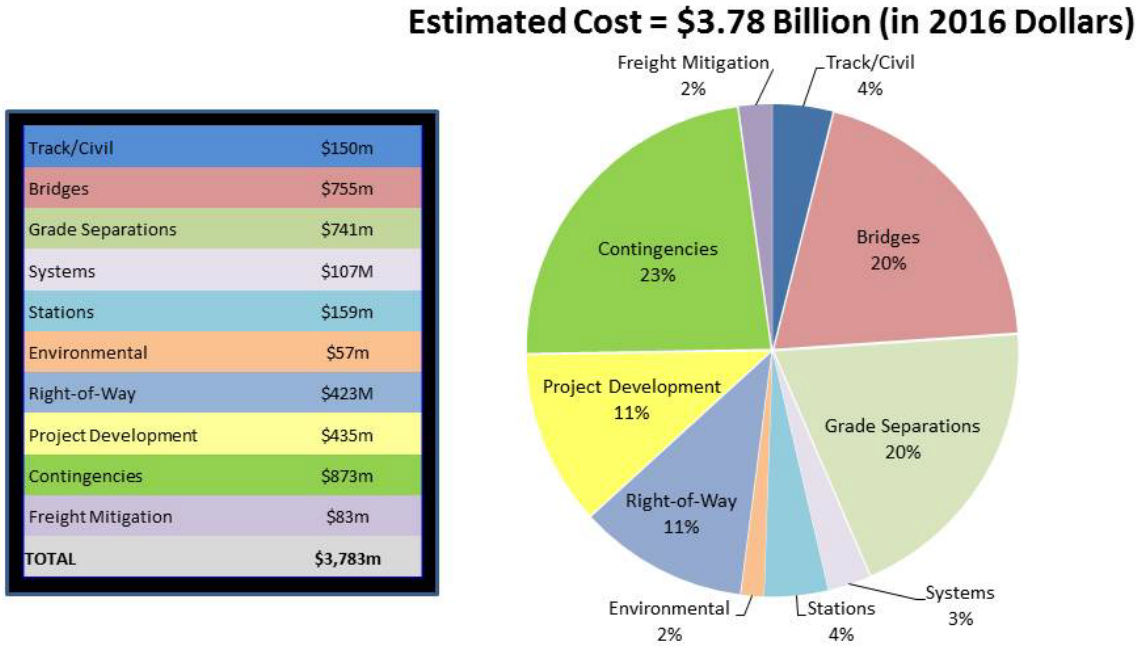
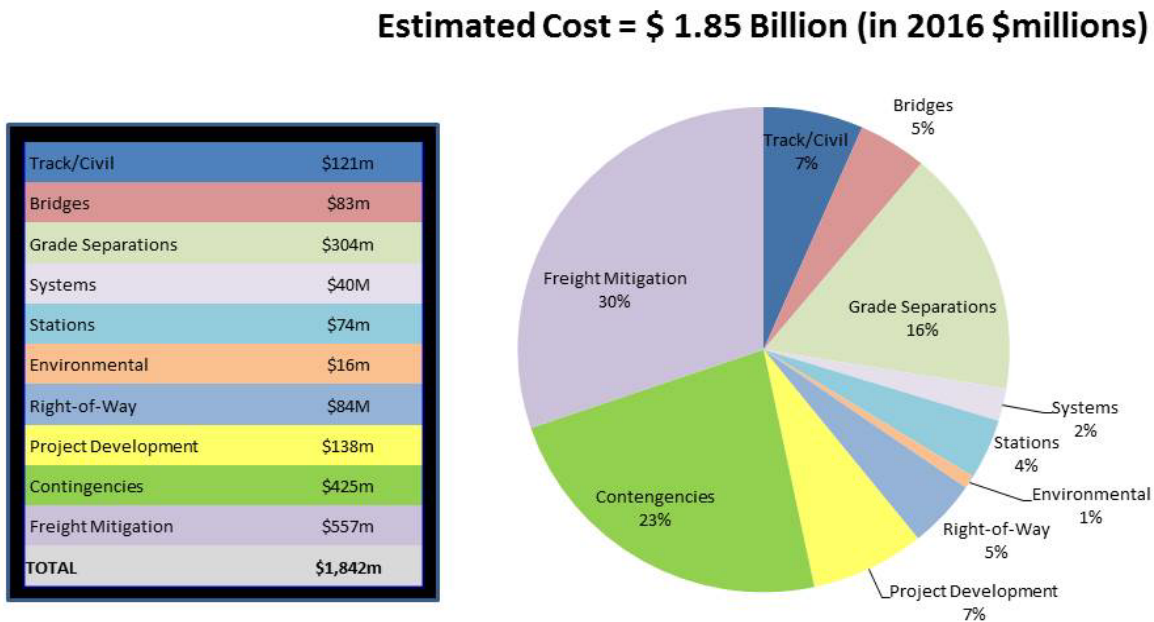

Figure 5-2: Oakland-Richmond Dedicated Passenger Corridor



A significant portion of Phase 2 project costs are committed to grade separations and improving goods movements in the East Bay, approximately \$1.05 Billion and \$640 Million, respectively.

Figures 5-3 and 5-4 summarize the major cost components of Phase 3 (3a and 3b) of the implementation plan in 2016 dollars.



Figure 5-3: Jack London Square Tunnel

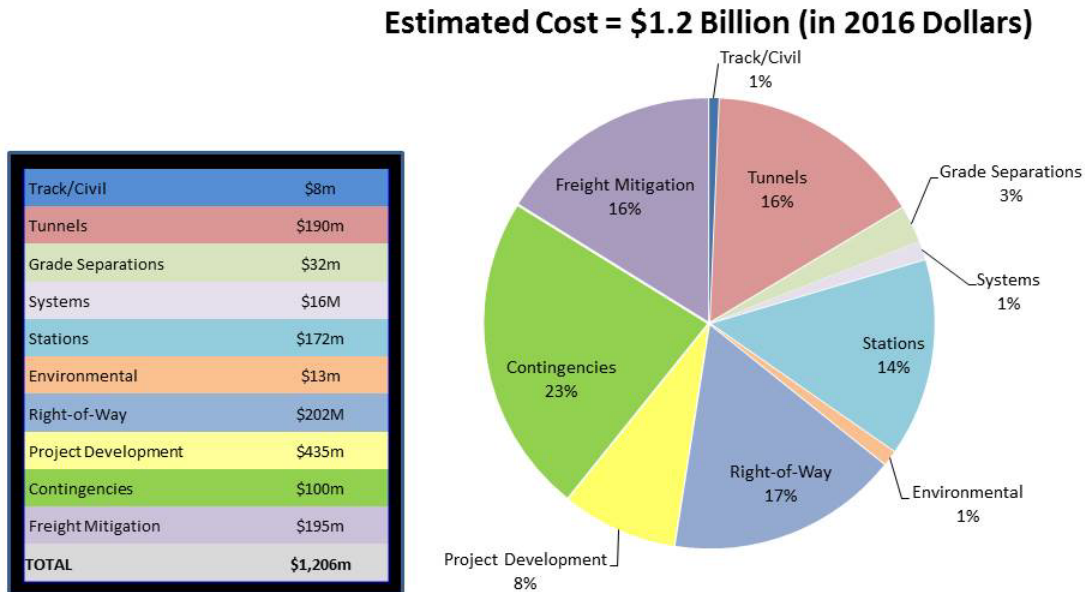
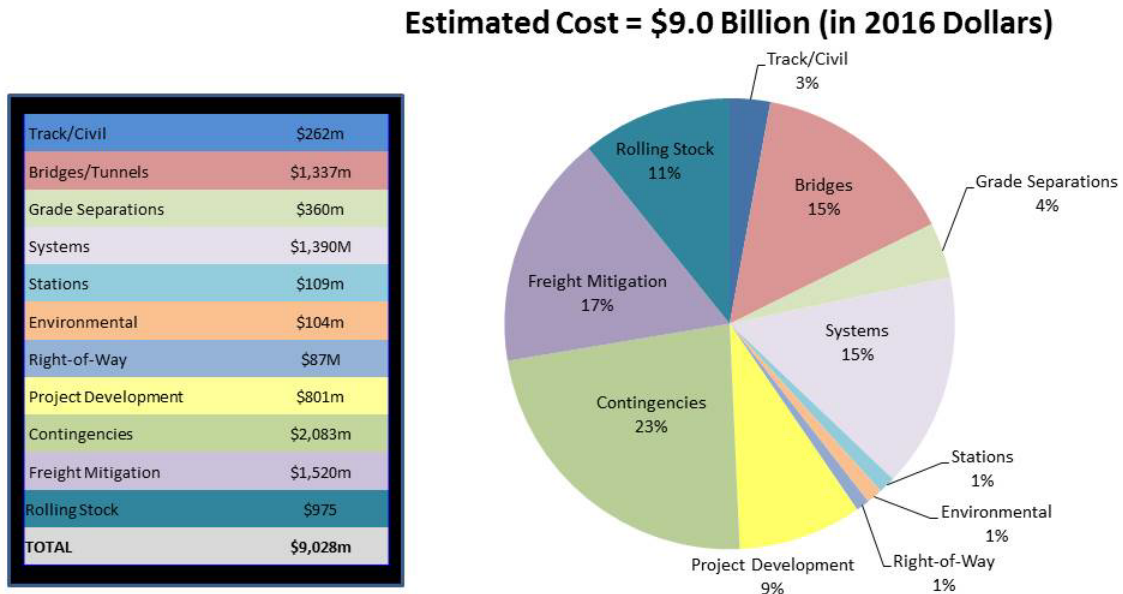

Figure 5-4: Richmond-Sacramento Dedicated Passenger Corridor



Completion of Phase 3a creates separate grade-separated passenger and freight lines through Jack London Square including a new underground station centered on Broadway Street at an estimated cost of \$1.2 Billion. If funding becomes available sooner, the project can be advanced ahead of Phase 2b. Significant service benefits from the project are only possible if Phase 2a is completed.

Phase 3b achieves the CCJPA’s vision of a modern electrified passenger rail system between San Jose and Sacramento at speeds of 125 mph, but at a significant cost, approximately \$9.0 Billion. The major cost elements of this phase of the VIP are \$2.37 Billion for electrification and new trainsets, \$1.52 Billion to

replace the UPRR rail corridor between Martinez and Sacramento, and \$1.34 Billion for the Franklin Canyon Tunnel and new high-level crossing of the Carquinez Strait.

Table 5-3 VIP Passenger Order-of-Magnitude Project Costs

Items	Priority 1: Sacramento to Roseville 3rd Track	Priority 2: Santa Clara (CP Coast) to Oakland	Priority 3: Oakland to Richmond Passenger Dbl. Track	Priority 4: Jack London Station and Subway Tunnel	Priority 5: Richmond to Sacramento +Corridor Wide Electrification	Passenger Subtotals	Subtotal Passenger and Freight	Priority 6: Auburn Extension
Trackwork		\$115,300,000	\$78,000,000	\$6,700,000	\$215,400,000	\$415,400,000	\$654,300,000	\$66,300,000
Site Civil		\$34,400,000	\$43,100,000	\$1,000,000	\$46,900,000	\$125,400,000	\$248,900,000	\$29,200,000
Structures		\$755,100,000	\$83,400,000	\$190,200,000	\$1,336,700,000	\$2,365,000,000	\$3,043,400,000	\$147,900,000
Grade Separations		\$740,000,000	\$304,000,000	\$32,000,000	\$360,000,000	\$1,436,000,000	\$1,924,000,000	\$272,000,000
Systems		\$106,600,000	\$39,500,000	\$16,400,000	\$1,390,200,000	\$1,552,700,000	\$1,754,100,000	\$634,200,000
Roadway		\$1,000,000				\$1,000,000	\$21,000,000	\$2,000,000
Stations and Facilities		\$159,300,000	\$74,000,000	\$171,500,000	\$108,800,000	\$513,600,000	\$513,600,000	\$107,000,000
Environmental Mitigation		\$57,400,000	\$16,200,000	\$12,500,000	\$103,700,000	\$189,800,000	\$242,600,000	\$37,800,000
Subtotal Construction Costs		\$1,969,100,000	\$638,200,000	\$430,300,000	\$3,561,700,000	\$6,599,300,000	\$8,401,600,000	\$1,296,400,000
Right-of-way		\$422,800,000	\$84,100,000	\$201,600,000	\$86,600,000	\$795,100,000	\$960,100,000	\$191,000,000
Rolling Stock					\$975,000,000	\$975,000,000	\$975,000,000	
<b>Subtotal Base Project Costs</b>		<b>\$2,391,900,000</b>	<b>\$722,300,000</b>	<b>\$631,900,000</b>	<b>\$4,623,300,000</b>	<b>\$8,369,400,000</b>	<b>\$10,336,700,000</b>	<b>\$1,487,400,000</b>
Program Management (5% Base Project)		\$119,600,000	\$36,100,000	\$31,600,000	\$231,200,000	\$418,500,000	\$516,900,000	\$74,400,000
Environmental Clearance (3% Constr. Cost)		\$59,100,000	\$19,100,000	\$12,900,000	\$106,900,000	\$198,000,000	\$252,100,000	\$38,900,000
Engineering (6% Constr. Cost)		\$118,100,000	\$38,300,000	\$25,800,000	\$213,700,000	\$395,900,000	\$504,000,000	\$77,800,000
CI&E (7% Constr. Cost)		\$137,800,000	\$44,700,000	\$30,100,000	\$249,300,000	\$461,900,000	\$588,100,000	\$90,700,000
Contingencies (30% of above)		\$848,000,000	\$258,200,000	\$219,700,000	\$1,627,300,000	\$2,953,200,000	\$369,500,000	\$530,800,000
<b>Subtotal in 2016 Dollars</b>	<b>\$235,000,000</b>	<b>\$3,674,500,000</b>	<b>\$1,118,700,000</b>	<b>\$952,000,000</b>	<b>\$7,051,700,000</b>	<b>\$12,796,900,000</b>	<b>\$15,857,300,000</b>	<b>\$2,300,000</b>
<i>Construction Year (Mid Point)</i>	<i>2018</i>	<i>2025</i>	<i>2030</i>	<i>2035</i>	<i>2040</i>			<i>2050</i>
Construction Escalation (@ 3%/yr.)	\$14,300,000	\$1,119,900,000	\$573,400,000	\$717,300,000	\$7,238,000,000	\$9,693,300,000	\$12,328,800,000	\$3,983,400,000
<b>Total Passenger Service Cost</b>	<b>\$249,300,000</b>	<b>\$4,794,400,000</b>	<b>\$1,692,100,000</b>	<b>\$1,669,300,000</b>	<b>\$14,334,700,000</b>	<b>\$22,490,500,000</b>	<b>\$ 28,186,100,000</b>	<b>\$6,283,400,000</b>

Note: Costs rounded to nearest \$100,000

Table 5-4 Freight Mitigation Order-of-Magnitude Project Costs

Items	Priority 2: Oakland/Niles Subdivision Freight Railroad Connections	Priority 3: Oakland/Niles Double Track Project	Priority 4: Jack London Trench/Tunnel Project	Priority 5: Martinez to Sacramento Freight Railroad	Freight Subtotals
Trackwork	\$20,000,000	\$19,500,000	\$4,600,000	\$194,800,000	\$238,900,000
Site Civil	\$3,900,000	\$7,900,000	\$42,200,000	\$69,500,000	\$123,500,000
Structures	\$25,200,000	\$7,800,000	\$107,000,000	\$538,000,000	\$678,000,000
Grade Separations		\$392,000,000	\$	\$96,000,000	\$488,000,000
Systems	\$10,000,000	\$15,500,000	\$2,300,000	\$173,600,000	\$201,400,000
Roadway	\$2,000,000	\$4,000,000		\$14,000,000	\$20,000,000
Stations and Facilities					
Environmental Mitigation	\$1,800,000	\$13,400,000	\$4,700,000	\$32,600,000	\$52,500,000
<b>Subtotal Construction Costs</b>	<b>\$62,900,000</b>	<b>\$460,100,000</b>	<b>\$160,800,000</b>	<b>\$1,118,500,000</b>	<b>\$1,802,300,000</b>
Right-of-way	\$6,500,000			\$158,500,000	\$165,000,000
Rolling Stock					
<b>Subtotal Base Project Costs</b>	<b>\$69,400,000</b>	<b>\$460,100,000</b>	<b>\$160,800,000</b>	<b>\$1,277,000,000</b>	<b>\$1,967,300,000</b>
Program Management (5% Base Project)	\$3,500,000	\$23,000,000	\$8,000,000	\$63,900,000	\$98,400,000
Environmental Clearance (3% Constr. Cost)	\$1,900,000	\$13,800,000	\$4,800,000	\$33,600,000	\$54,100,000
Engineering (6% Constr. Cost)	\$3,800,000	\$27,600,000	\$9,600,000	\$67,100,000	\$108,100,000
CI&E (7% Constr. Cost)	\$4,400,000	\$32,200,000	\$11,300,000	\$78,300,000	\$126,200,000
Contingencies (30% of above)	\$24,900,000	\$167,000,000	\$58,400,000	\$456,000,000	\$706,300,000
<b>Subtotal in 2016 Dollars</b>	<b>\$107,900,000</b>	<b>\$723,700,000</b>	<b>\$252,900,000</b>	<b>\$1,975,900,000</b>	<b>\$3,060,400,000</b>
<i>Construction Year (Mid Point)</i>	<i>2025</i>	<i>2030</i>	<i>2035</i>	<i>2040</i>	
Construction Escalation (@ 3%/yr.)	\$32,900,000	\$371,000,000	\$190,600,000	\$2,040,700,000	\$2,635,200,000
<b>Total Freight Mitigation Cost</b>	<b>\$130,000,000</b>	<b>\$1,094,700,000</b>	<b>\$443,500,000</b>	<b>\$4,016,600,000</b>	<b>\$5,695,600,000</b>
<b>Total Project Development Cost</b>	<b>\$4,555,500,000</b>	<b>\$2,786,800,000</b>	<b>\$2,112,800,000</b>	<b>\$18,351,300,000</b>	<b>\$28,186,100,000</b>

Note: Costs rounded to nearest \$100,000

## 6 FUNDING OPTIONS

This appendix provides a preliminary assessment of potential funding options for the improvements described in the Capitol Corridor Vision Implementation Plan (CCVIP), with a focus on property-based funding sources such as special taxes, special assessments, development impact fees and tax increment financing tools. The memo focuses on the Capitol Corridor transit improvements, and does not consider potential funding sources for related improvements to freight rail.

The appendix is organized in the following sections:

- A summary of funding needs included in the Capitol Corridor Vision Implementation Plan;
- An overview of federal, state and local capital funding sources for transit;
- Details about a range of property-based funding sources and their applicability to planned Capitol Corridor improvements; and
- Conclusions about the categories of improvements that are most likely to be funded using property-based sources.

A matrix with information about all of the property-based funding sources discussed in this memo is provided at the conclusion of this appendix.

### SUMMARY OF FUNDING NEEDS

The CCVIP incorporates a variety of capital improvements, some of which are corridor-wide, while others are location specific. These improvements are summarized in Table 1, on the following page.



**Table 6-1 Major Improvements in the Capitol Corridor Vision Implementation Plan**

Location	Planned Improvements
Corridor-wide	Electric train infrastructure
	Upgraded signaling systems
	Curve straightening/grade leveling
	Enhancements to existing stations
	Grade-separation of at-grade intersections
San Jose-Oakland	New storage and maintenance facility near Tamien Station
	Improvements to Diridon Station
	Additional tracks
	Reconstruction of the Santa Clara Station
	Double-tracking of some segments
	Possible new station at Dumbarton Bridge
	A new viaduct in the Oakland Subdivision
	New intermodal Oakland Coliseum station
Jack London District	Tunnel below 2nd Street (and possible freight rail tunnel beneath Embarcadero)
	New subway station (in conjunction with second Transbay Tube)
Oakland-Richmond	Expansion of existing right-of-way
	Rebuild existing stations
	Possible new stations
Richmond-Suisun/Fairfield	Franklin Canyon Tunnel
	New Carquinez Straight crossing
Suisun/Fairfield-Sacramento	Tunnel under Downtown Sacramento (in conjunction with high-speed rail)

## OVERVIEW OF CAPITAL FUNDING SOURCES

Funds from a wide variety of federal, state and local sources might be used to help pay for the improvements envisioned in the CCVIP. Historically the CCJPA has primarily relied upon state sources with very minor use of any federal sources for capital improvements, however the availability of funding from state sources has diminished over time, and shifted to become more competitive.<sup>1</sup>

---

<sup>1</sup> Capitol Corridor Joint Powers Authority, Capitol Corridor Intercity Passenger Rail Service Business Plan Update FY 2016-17 – FY017-18, February 2016.

## Federal

Federal funding is typically an important source for major transit capital projects such as the ones outlined in the CCVIP. The Fixing America's Surface Transportation (FAST) Act will provide up to \$305 billion for transportation over five years. While the FAST Act provides for funding specifically for state supported intercity passenger rail services such as the Capitol Corridor, funds have yet to be appropriated, and thus the outlook for federal funding for Capitol Corridor improvements is uncertain.

## State

The primary source of state funding for the Capitol Corridor has historically been the State Transportation Improvement Program (STIP), specifically the Interregional Transportation Improvement Program (ITIP), which represents 25 percent of the STIP and is used to fund projects that connect metropolitan areas. Over time, changes to the funding allocation formulas, combined with reductions in the amount of state funding for transit, have resulted in very limited funding for needed Capitol Corridor improvements. Bond measures which included provisions for the state intercity passenger rail program have also played a significant role but those sources have been one-time in nature and not a dedicated funding stream on which to build a capital program.

With limited STIP funds, state bonds and grants have become more critical components of Capitol Corridor funding. Proposition 1B provided nearly \$20 billion in funds for transit, however these funds have now nearly all been expended. CCJPA's allocation of Proposition 1A funds are now fully committed toward Capitol Corridor improvements for phase one of a service expansion between Sacramento and Roseville and to a lesser extent for a travel time savings project. The state Cap and Trade program is another important source; CCJPA has been successful at receiving small scale grants of the Transit Intercity Rail Capital Program (TIRCP) for the aforementioned travel time savings project (TIRCP year one) and service expansion between Sacramento and Roseville (year two TIRCP). However, in total those TIRCP funds have only amounted to under \$14 million for the CCJPA. In the future, it is possible that the program will allow multi-year allocations for some projects, however the viability of the TIRCP and Cap and Trade program as a significant capital funding source is in jeopardy due to the Cap & Trade carbon auction market under achieving on anticipated projections.

## Local

Given the limitations on federal and state funding, local funding for transit has grown in importance over time, most notably county sales tax measures. Identifying local funding sources is also critical because federal and state discretionary grant programs favor projects that can illustrate a high level of local commitment.

Local funding can come from a variety of sources. The biggest source of local funding in California by far is local sales tax measures. Counties and special districts (such as BART) can adopt sales tax increases for transportation purposes, subject to a 2/3 local voter approval. Sales tax measures offer the benefit of drawing from a relatively broad area, and can include a variety of improvements that, when combined, will appeal to a wide range of voters.

In addition to sales tax measures, recent years have seen increased interest in the use of property-based funding sources such as special taxing districts, tax increment financing and developer fees.

Additional detail about these sources and their potential to help fund Capitol Corridor improvements is discussed in the section below. While they are sometimes discussed together, it is important to distinguish between property-based funding sources and public-private partnerships (PPPs). A PPP is a method of project delivery wherein private and public sector entities enter into a partnership to provide public improvements. Typically, the private party will provide the improvements and bear some of the financial and/or operational risk in the project, in some cases including financing (e.g., debt).

## Property-Based Funding Sources

Property-based funding mechanisms – also sometimes referred to as “value capture” mechanisms -- include a variety of tools that are employed by the public sector at the local level. These tools are attracting increased interest in transit finance circles, in part due to the limitations on of state and federal funding. A strong rationale exists for the use of property-based tools to help fund transit projects, since many studies show that transit investments have the potential to positively impact nearby property values and development potential. Unless this value is captured through a tax or other mechanism, this increase in value represents a “windfall gain” for property owners.

The planned Capitol Corridor improvements will generate a wide range of economic benefits. Many of the benefits will accrue to the broader megaregion: enhancements to the system will help to promote economic development by linking high tech clusters, research institutions and supporting industries; improving access to labor; facilitating goods movement; making the megaregion more competitive and diversifying local economies. Households and workers will benefit from reduced transportation costs and access to a greater number of jobs. And finally, some benefits will accrue to nearby property owners in the form of enhanced property values and improved development potential. Where this occurs there may be potential for property-based funding sources.

In general, property-based tools fall into four categories: special assessments and taxes, tax increment financing (TIF), direct developer contributions (including development impact fees, negotiated developer contributions, and community benefits/density bonus programs), and public sector real estate transactions. The tools available in California are described below, along with an initial assessment of their applicability to the Capitol Corridor. A detailed table comparing the tools is provided as an appendix.

## Community Facilities Districts

A **Mello-Roos Community Facilities District (CFD)** is a type of special taxing district formed when property owners or registered voters within a geographic area agree to impose a new tax on property in order to fund infrastructure improvements, public facilities or certain public services. It is important to note that a CFD may not be used to fund ongoing transit service or maintenance of transit facilities.

A CFD can be formed by a city, county, joint powers authority or other special district. Tax revenues can be collected and used on a pay-as-you-go basis (over time), or serve as the basis to issue a bond. CFDs are relatively flexible in their application, and the special tax rates may be set on any reasonable basis determined by the local legislative body (e.g., on the basis of building area, parcel size, or linear feet of parcel frontage), except that the tax cannot be *ad valorem* (based on property value). CFD boundaries can be drawn to include non-contiguous parcels, and

different special tax rates can be set for different parcels within the CFD, based on land use/property type, distance from a transit station, densities, or other material factors.

A CFD requires approval by two-thirds of property owners (weighted by property area) so long as there are no more than 12 registered voters living within the proposed boundary. If there are more than 12 registered voters living within the district, the formation of a CFD requires two-thirds voter approval.

*Potential Use for Capitol Corridor: **Possible***

CFDs are typically used within a relatively small district, where property owners will see a direct benefit from improvements. It is possible that a CFD could be used to assist with improvements at individual stations, particularly to help fund a new station or enhancement to an existing station.

### **Special Assessment Districts**

**Special Assessment Districts** are designated districts where property owners agree to pay an additional assessment in order to fund specific improvements or services. California law defines a number of different types, including Lighting and Landscaping Districts, Parking Districts, Transit Benefit Assessment Districts and Property-Based Business Improvement Districts. The general characteristics of Special Assessment Districts are described below, followed by additional detail about the most relevant types of assessment districts that might be used for Capitol Corridor improvements.

An assessment district may be created by a city, county, joint powers authority or other special district. Districts are established by a vote of the property owners and require support from owners of a simple majority (50 percent plus one) of assessed property value in the district. However, under Proposition 218, a constitutional amendment passed by California voters in 1996, the amount that each property owner pays must be directly proportional to the “special benefit” the property will receive from the proposed improvement. The assessment district may not be used to pay for the portion of an improvement that accrues to the community at large (known as the “general benefit”).

Due to the special benefit requirement, assessment districts are typically used to fund small, primarily local-serving infrastructure such as landscaping, lighting, street, or sidewalk improvements. The Municipal Improvement Act of 1913 specifies that local governments may use special assessment districts to pay for public transit facilities (including stations, rolling stock and other equipment, and land acquisition) “designed to serve an area of not to exceed three square miles.”<sup>2</sup> Most types of assessment districts have the ability to issue tax-exempt bonds.

**Transit Benefit Assessment Districts (TBAD)** are a new form of special assessment district defined by state law, geared specifically toward transit funding. In 2013, SB142 authorized municipal transit operators and other transit agencies to create special benefit districts within a half mile of transit stations specifically to assist in funding the development of transit stations and rail facilities. Unfortunately, Transit Benefit Assessment Districts are subject to the same constraints imposed by Proposition 218: the improvements and services funded by the district must provide a direct and special benefit to the properties subject to the assessment, over and

---

<sup>2</sup> State of California, Streets and Highways Code, Section 10100.5.

above any general benefit to transit riders accessing the station, other property owners, or the public at large.

**Property-Based Business Improvement Districts (PBID)** (also called Community Benefits Districts within some jurisdictions, including Oakland and San Francisco) are distinct from other types of districts because they are managed by a board comprised of property or business owners. These districts typically focus on providing services within a commercial business district.

*Potential Use for Capitol Corridor: **Possible***

The special benefit requirement imposed by Proposition 218 places some significant limitations on the use of special assessment districts for transit purposes. Arguably, many of the benefits of transit accrue to the general public. In most cases, a CFD offers greater flexibility and has the potential to generate greater revenues (as long as the higher voter threshold can be met).

The TBAD tool does offer the advantage of being designed specifically for transit use, although no districts have been created to date under the legislation. BART is currently in the process of exploring opportunities to pioneer the use of TBADs within the BART system. Initial research suggests that the tool is most likely to be used for transit-related projects that directly benefit property owners, such as pedestrian improvements, lighting and landscaping, and shuttles or other transportation demand management systems. As BART moves forward in its efforts to implement a TBAD, this may provide greater clarity about ways it might help to provide funding for Capitol Corridor improvements.

## **Parcel Taxes**

A **parcel tax** is a special tax that is levied on properties within a city, county, community college or school district, or other special district. The tax must be based on characteristics of the parcel, rather than on the value of the property being taxed. In California, parcel taxes must be approved by two-thirds of voters within the affected area. They are most commonly used to pay for schools, but may be imposed for a wide variety of purposes, including transit and other transportation uses. The Alameda-Contra Costa Transit District (AC Transit) is funded in part through a parcel tax that has been increased and extended by voters multiple times. However, over time AC Transit appears to be relying increasingly upon funding from county-wide sales tax measures instead of parcel taxes.

*Potential Use for Capitol Corridor: **Unlikely***

Parcel taxes are not commonly used to fund transit and instead are used to help pay for schools, fire, police and other basic services. Because a parcel tax requires a “supermajority” vote, it can be challenging and costly to institute. Sales tax measures are a more common source of funding for transit. One challenge of parcel taxes is because they are charged on a parcel basis, they tend to place a higher burden on residential properties than commercial properties.

## **Enhanced Infrastructure Financing Districts**

Tax increment financing tools divert incremental growth in tax revenues from taxing entities within a district. In California, new TIF tools have recently been created after the dissolution of redevelopment, however examples of their use remain very limited.

Established in 2014, **Enhanced Infrastructure Financing Districts (EIFDs)** are designed to capture incremental growth in property tax revenues over a base year. Revenues may be used



to fund the acquisition or construction of public facilities and infrastructure. The EIFD is governed by a specially constituted public financing authority comprised of elected officials from the participating taxing entities and appointed members of the public. Participating taxing entities may choose to allocate a share of revenues from several other sources in addition to property tax increment. Voter or property owner approval is not required to establish the district, but a 55 percent vote is required prior to bond issuance. If 12 or more registered voters live within the district boundaries, approval by those registered voters is required. Otherwise, the vote is by the property owners in the district.

*Potential Use for Capitol Corridor: **Possible***

Tax increment financing works best in locations where significant development is planned on the near horizon. As such, this tool could best be used to help fund improvements in specific station areas where development is planned. Where Capitol Corridor improvements help to create new development opportunities, it can help to create a rationale for the creation of an EIFD to help fund those improvements.

### **Community Revitalization and Investment Authorities**

Authorized by the State of California in September 2015, a **Community Revitalization and Investment Authority** (CRIA) is a new type of tax increment financing tool targeting very distressed areas.

A CRIA can be created by a city county or joint powers authority, following a “majority protest proceeding”, as long as voters and property owners do not terminate the CRIA through a protest ballot. In addition, affected taxing entities must consent to allocate a share of incremental property tax revenues to the authority. CRIAs may only be formed in areas that meet selected criteria, including lower than average median household incomes, high unemployment and crime rates, and inadequate infrastructure.

A CRIA may provide funding for infrastructure improvements, affordable housing, property acquisition, brownfield cleanup, loans or grants for property owner and tenant improvements, and other specified purposes. The authority may pay for improvements on a pay-as-you-basis, or finance improvements by issuing bonds. Twenty-five percent of revenues must be set aside to pay for low- and moderate-income housing.

*Potential Use for Capitol Corridor: **Unlikely***

CRIA legislation was designed specifically to provide funding for infrastructure to revitalize low-income neighborhoods, and 25 percent of revenues generated must go toward affordable housing. Where a TIF tool can be used, an EIFD will be better suited to Capitol Corridor improvements. Moreover, because this tool targets areas with specific income, crime, unemployment and other characteristics, it will also not be possible to use it in many locations along the Capitol Corridor.

### **Development Impact Fees**

A **development impact fee** is a one-time charge to new development, designed to mitigate impacts directly resulting from development activity, and cannot be used to fund existing infrastructure deficiencies (i.e., repair or maintenance of existing infrastructure). Where improvements will benefit existing as well as new development, impact fees can only pay for the portion of the improvement that benefits the new development.

Impact fees do not require voter or property owner approval, but must be adopted based on findings of a “nexus” (or reasonable relationship) between the development paying the fee, the size of the fee, and the use of fee revenues. Because impact fees are dependent on new development projects, they are not usually consistent or predictable enough to serve as security for the issuance of bonds.

San Francisco recently approved a new “transportation sustainability fee”, designed to generate revenues to invest in the city’s transportation network, including both Muni and BART.

*Potential Use for Capitol Corridor: **Possible***

It is possible that a development impact fee could help to pay for some specific Capitol Corridor improvements, if it can be shown that the enhanced access provided by the Capitol Corridor is needed to support new development. A nexus study would need to show that the fee would pay for a transit improvement that would mitigate a need generated by future new development.

Development fees are typically implemented within a single jurisdiction, and sometimes within a smaller district. Transit agencies do not have the authority to impose impact fees. This tool is most likely to be used in conjunction with a city such as Oakland, San Jose or Sacramento, where transit improvements will help to enable more intensive development.

### **Community Benefits Program/ Development Agreement**

Local jurisdictions in California can also obtain funding for local infrastructure through a community benefits program or development agreement. Cities may directly negotiate with individual developers as they seek entitlements, or create a community benefits program that provides a structure for developer contributions, typically in exchange for additional density and/or height. Under these programs, development may be eligible for a pre-defined increase in density or floor area ratio (FAR) in exchange for providing public benefits (which may be selected from a list of improvements), or funding at a pre-determined, per-square-foot price (which the city uses to pay for district-wide improvements).

*Potential Use for Capitol Corridor Improvements: **Possible (But Limited)***

In certain circumstances it may be possible to negotiate with major property owners to contribute to station area improvements, particularly in locations where transit improvements are accompanied by rezoning, or where major development projects are planned. The CCJPA would need to work closely with a city to include transit improvements in negotiations.

### **Public Section Real Estate Strategies**

Transit agencies and other public entities can also generate revenues through management of their real estate assets. Revenues may be generated through a land sale, ground lease, sale of “air rights” or other type of transaction involving publicly-owned land. However, public agencies also face limitations on how they may use or dispose of property. For example, the California Surplus Lands Act places specific requirements on cities and counties that choose to sell surplus properties, including requiring that a right of first refusal be offered to affordable housing developers. Similarly, where transit agencies used federal funds to purchase land, they face some restrictions on how the proceeds from a land sale may be used.

*Potential Use for Capitol Corridor: **Possible***

Opportunities may exist to leverage properties owned by the Capitol Corridor or other public entities to generate value through sale of land or air rights, however this source is not likely to generate enough revenue to constitute a major source of capital funding.

## CONCLUSION

Table 2 summarizes preliminary findings about the potential use of property-based tools to pay for the capital investments described in the CCVIP. Improvements are grouped in categories that are relevant for funding, taking into consideration geographic scale, whether the improvement is likely to have a direct impact on nearby property owners and development potential, and characteristics of the funding tools. Tunnels were listed separately from bridges, viaducts and other major improvements because in some locations (e.g., Oakland's Jack London District) they have the potential to impact street-level activity and development potential. Each of the categories is discussed in greater detail below.

**Table 6-2 Summary of Potential for Property-Based Funding**

Category	Description/Example	Potential for Property-Based Funding
Corridor-wide improvements	Electric train infrastructure	Limited
	Upgraded signaling systems	
	Curve straightening/grade leveling	
	Intersection improvements (grade separation)	
New storage and maintenance facility	New facility near Tamien Station	Limited
Improvements to existing stations	Enhancements to existing stations	Possible
	Santa Clara Station reconstruction	
	Improvements to Diridon Station to allow it to function as a high-capacity hub	
New stations	New station near Dumbarton Bridge	Possible
	New station(s) in Oakland-Richmond segment	
	New intermodal Oakland Coliseum station	
	New JLS subway station (in conjunction with second Transbay Tube)	
New bridges and viaducts	New viaduct in the Oakland Subdivision	Limited
	New Carquinez Straight crossing	
New tunnels	Jack London District - tunnel below 2nd Street (and possible freight rail tunnel beneath Embarcadero)	Possible but limited relative to total cost
	Tunnel under Downtown Sacramento	
	Franklin Canyon tunnel	
Additional tracks, double tracking and expansion of existing right-of-way	New tracks in Oakland-San Jose segment	Limited
	Oakland-Richmond segment ROW improvements	

- **Corridor-wide improvements:** Investments at the corridor-level are least likely to be funded using property-based funding sources, because the improvements will generate benefits throughout the entire corridor, rather than in a specific area. A parcel tax at the county or county sub-district level could in theory help to fund this scale of improvements, however there is limited precedent for this, and it could be very difficult to obtain the 2/3 vote necessary to institute the tax. While AC Transit has been successful in passing parcel taxes to help fund transit, the service they provide is spread more evenly throughout a broader service district. It is also possible that a city-sponsored transportation impact fee could contribute funding to corridor-level improvements.
- **Storage and maintenance facility:** While the planned facility is technically located within one city/neighborhood, it nevertheless serves a function that is corridor-wide. In theory a parcel tax or development impact fee might be structured to help pay for a portion of the facility. Local district-based financing tools such as a CFD, SAD or EIFD are unlikely sources.
- **Improvements to existing stations:** Station improvements that generate value for the surrounding neighborhood, including improved lighting, streets, sidewalks or other benefits, offer potential for a CFD or SAD. Both of these tools require a vote, and therefore must have local support. Similarly, an EIFD could help to pay for station improvements, but a 55 percent vote would be required to issue a bond based on the revenues generated. In theory, an impact fee could also contribute to station improvements, if the city were to choose to implement a fee, and if it could be shown that the improvements mitigate a transportation need generated by new development (see new stations, below).
- **New stations:** New stations create a strong rationale for property-based financing tools, because they offer a clear benefit to adjacent property owners who previously did not have direct access to the transit service. In some cases, property owners may be willing to contribute in the form of a special assessment or special tax (CFD). The city and other taxing entities may in some cases also be willing to assist with funding improvements through an EIFD or by instituting a development fee. It is important to note that all of these tools are most likely to be viable in locations with relatively strong real estate markets and significant development opportunities.
- **New bridges and viaducts:** Similar to the maintenance facility discussed above, it is unlikely that nearby property owners will vote to assist with funding a nearby elevated transitway. These types of improvements might be included as part of a development fee, or there may be circumstances where a bridge or viaduct is part of a broader set of improvements that help to create development opportunities, and thus might be partially funded through an EIFD.
- **New tunnels:** in most cases, the potential to fund tunnels using property-based sources is likely to be similar to bridges and viaducts above (i.e., limited). However, to the extent that relocating trains underground has a positive impact on surrounding properties – or helps to create new development opportunities – there may be opportunities to use a district-based financing mechanism such as a CFD, SAD or EIFD. In addition, it is conceivable that a city could contribute to the cost of a new tunnel through a development impact fee.
- **Additional tracks and expansions to right-of-way:** These types of improvements will be challenging to fund using property-based tools because they provide a benefit that

is system wide, rather than directly linked to specific properties or development opportunities.

Broadly, the Capitol Corridor investment – and the many far reaching economic benefits it will provide – suggests state or county-level funding sources as the most appropriate. However, this preliminary analysis suggests that there are some circumstances where property-based tools should be considered. Most property-based tools require consent by property owners (or voters), and thus are most likely to be successful where there is a clear value proposition for nearby property owners, particularly where the improvements will directly help to create or enhance development opportunities. For the same reason, these funding sources are more likely to be viable in relatively strong real estate markets. Because the potential for these funding sources depends on the land use and market context, funding opportunities will require further study as the CCJPA proceeds with the project. However, this memo can serve as a preliminary guide for identifying the most likely opportunities for the use of property-based funding sources.



Table 6-3 Property-Based Funding Mechanisms in California

Mechanism	Administering Entity	Geographic Scale	Revenue Source	Voting Requirements	Nexus or Special Benefit Requirement? <sup>(a)</sup>	Permitted Uses of Funds
Mello-Roos Community Facilities District (CFD)	City, county, special district, school district, joint powers authority	District	Special tax on property	2/3 of property owners or registered voters <sup>(b)</sup>	No	Construction or acquisition of public facilities (e.g., transit, parks, schools, libraries). May also fund specified ongoing services (e.g., fire, police, lighting). May not fund transit operations.
Special Benefit Assessment District	City, county, special district, or transit agency	District; occasionally jurisdiction-wide	Assessment, usually of property	50% plus one of property owners (weighted by financial obligation of each property under proposed assessment)	Use of assessment must provide special benefit to property owners, and size of assessment must be proportional to special benefits received by property owners	Uses are specified in various assessment acts; typically includes local street, sidewalk, lighting and landscaping improvements and maintenance.
Transit Benefit Assessment Districts (TBADs)	Transit agency	District	Assessment of property	50% plus one of property owners (weighted by financial obligation of each property under proposed assessment)	Use of assessment must provide special benefit to property owners, and size of assessment must be proportional to special benefits received by property owners	Transit-related capital improvements and services. May not fund routine operations or maintenance of the transit system.
Property/Business Improvement District (PBID or BID); Community Benefit District (CBD)	Board comprised of business or property owners (or city or county)	District	Assessment of properties or businesses	50% plus one of property or business owners (weighted by financial obligation of each property or business under proposed assessment)	Use of assessment must provide special benefit to assesses, and size of assessment must be proportional to special benefits received by assessees	Districts may provide services that include safety, maintenance, marketing, capital improvements, economic development, and special events.
Parcel Taxes	City, county, special district, school district	Jurisdiction-wide	Special tax on property	2/3 of registered voters	No	Flexible; typically pay for local government services that benefit the community at large. Most commonly used for schools but have been used to fund transit and local infrastructure maintenance.
Enhanced Infrastructure Finance District (EIFD)	Established by a city or county; administered by a separate Public Financing Authority	District	Future increases in revenues from the existing property tax rate, as well as other specified sources	No vote required for formation; however, 55 percent of property owners or registered voters must approve issuance of tax increment bonds <sup>(c)</sup>	No	Construction or acquisition of public facilities and infrastructure, including transit facilities. May not fund routine operations or maintenance.
Community Revitalization and Investment Authority <sup>(d)</sup>	Established by a city, county, or joint powers authority	District	Future increases in revenues from the existing property tax rate	Protest process, and 50 percent plus approval by a combination of property owners and voters required in specific situations	No	Rehabilitation, repair, upgrade, or construction of infrastructure; may not be used to fund operations or maintenance.
Development Impact Fee	City, county, special district, school district	District or jurisdiction-wide	One-time fee on new development, authorized under the Mitigation Fee Act	None	Requires reasonable relationship ("nexus") between the development paying the fee, the size of the fee, and the use of fee revenues	Funds may only be used to mitigate impacts caused by new development, which may include impacts on a transit system.
Community Benefits Fee/Agreement	Land use authority (city or county)	Development site	Negotiated contribution or fee structure (e.g., through development agreement or conditions of approval)	None	No nexus required so long as contribution is voluntary	Negotiable.
Public Sector Real Estate Strategies (e.g. joint development, land sale)	Transit agency or other public land owner	Development site	Sale or ground lease of publicly owned land	None	No	May be subject to limitations, e.g., requirements for property purchased with federal dollars.

**Capitol Corridor Vision Implementation Plan | Final Report Appendices**  
 Capitol Corridor Joint Powers Authority

Mechanism	Administering Entity	Geographic Scale	Revenue Source	Voting Requirements	Nexus or Special Benefit Requirement? <sup>(a)</sup>	Permitted Uses of Funds
<p>Notes:</p> <p>Requirement for a "nexus" (or reasonable relationship) between the entities paying the fee, the amount they pay, and the benefit they receive, or a "special benefit" to the property owners subject to the assessment, over and above any general benefits to other property owners or the public at large.</p> <p>CFDs may be approved by a two-thirds majority of property owners in the proposed district, so long as there are no more than 12 registered voters living within the proposed boundary. If there are more than 12 registered voters living within the boundary, two-thirds approval by voters living within the district is required.</p> <p>Tax-increment bond issuances may be approved by a 55 percent majority of property owners in the proposed district, so long as there are no more than 12 registered voters living within the proposed boundary. If there are more than 12 registered voters living within the boundary, 55 percent approval by voters living within the district is required.</p> <p>Community Revitalization and Investment Authorities may only be formed in areas where the annual median household income is less than 80 percent of the statewide median, and three of the following four conditions are met: the unemployment rate is 3 percent higher than the statewide median; crime rates are 5 percent higher than the statewide median; infrastructure is deteriorated or inadequate; commercial or residential structures are deteriorated.</p> <p>Source: Strategic Economics, 2016. Adapted from "Value Capture Toolkit", prepared for the Metropolitan Transportation Commission by Strategic Economics, December 2015.</p>						

## 7 POTENTIAL IMPACTS OF BART PLANS

The Initial Study Corridor recommended by this effort includes a new, underground station at Jack London Square in Oakland. The precise location of this station is undefined. This is in part because of remaining uncertainty about whether BART will eventually construct a new line through Jack London as part of a second Transbay Tube project, and if so, which alignment it would follow. If BART were to add a station at Jack London, any new Capitol Corridor station should be connected to it. A second Transbay Tube could also, potentially, include standard-gauge tracks that could be used by Capitol Corridor trains or by other trains operating on Capitol Corridor tracks, impacting Capitol Corridor plans.

BART has studied second Transbay Tube alignments as part of the Vision and Core Capacity Study projects (the latter a collaboration with other agencies including MTC). Potential alignments it has studied would run north-south through Jack London, crossing a Capitol Corridor tunnel under Embarcadero or 2<sup>nd</sup>. Alignments that have been studied are under Franklin and extending from the Interstate 980 right-of-way under Howard Terminal.

An underground Capitol Corridor station at Jack London could connect to a Jack London BART station along either of these alignments, via pedestrian tunnels and vertical circulation. As BART trains would be just a few minutes from San Francisco at this point, this would become an intermodal hub of regional significance, providing access into San Francisco, via a relatively seamless transfer, from as far away as Sacramento. Capitol Corridor riders could also easily connect to BART stations along the new BART line in Downtown Oakland.

Inclusion of standard-gauge tracks in a second Transbay Tube could have a greater impact on Capitol Corridor plans and operating patterns. A branch from the tube extending under Alameda Point and Mandela Parkway in West Oakland, for example, could allow direct standard-gauge service from Emeryville to San Francisco (and potentially beyond the city, to the Peninsula and South Bay, if the Tube connected to the Caltrain corridor at the Transbay Transit Center). If such a plan were to be adopted, the Initial Study Corridor would need to adapt to it.